

Electrical Guide

Models - M2106, M2112, 108SD, 114SD

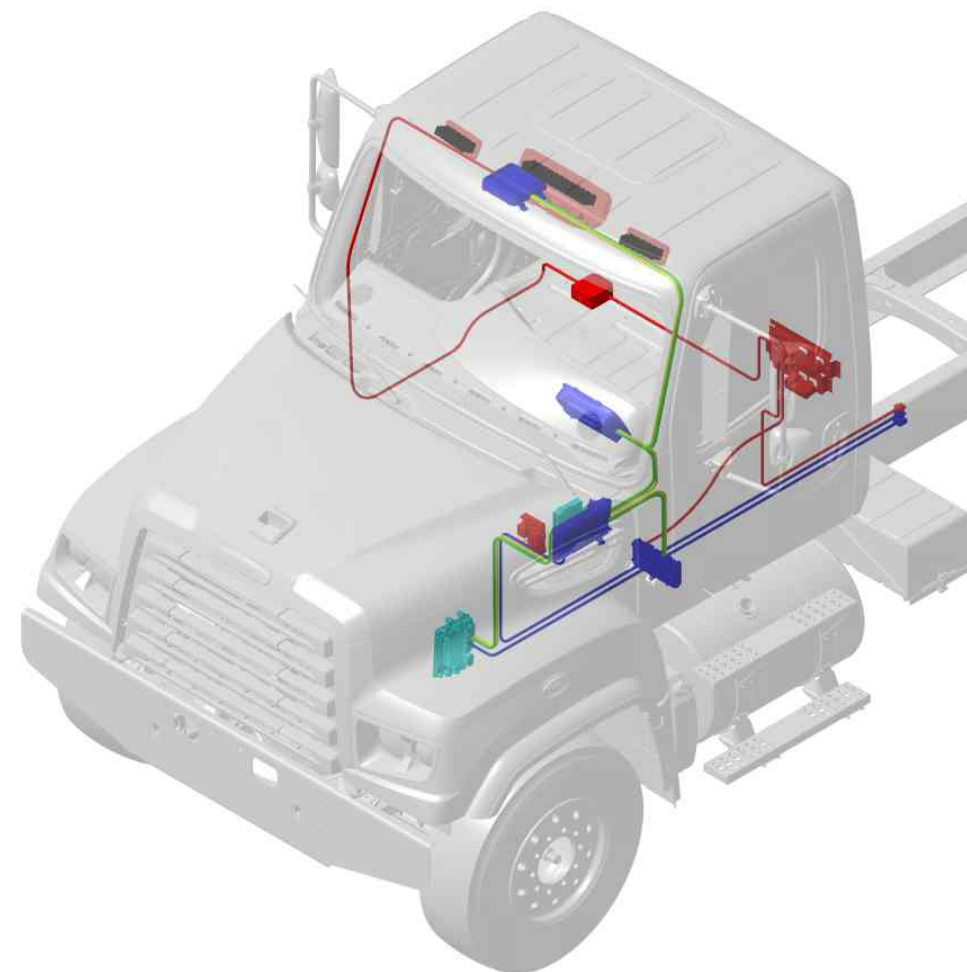

Body Builder Reference Guide

Revision - B - 12/1/15



Electrical Harness Overview

Index

Page 2	Index	Page 25	Body Lighting Interface Schematics
Page 3	Electrical Component Overview	Page 26	Trailer PDM
Page 4	Electrical Harness Overview	Page 27	Trailer Electrical Schematics (Seperate)
Page 5	Electrical Power flow Overview	Page 28	Trailer Electrical Schematics (Combination)
Page 6	PNDP Power Net Distribution Box	Page 29	Trailer and Floor connections
Page 7	Positive Disconnect Switch	Page 30	Tail Lights
Page 8	Main Power Distribution Module (PDM)	Page 31	Tail Light Schematics
Page 9	PDM / VBAT Fuse Coverage	Page 32	Transmission Interface
Page 10	Bulk Head Module (BHM)	Page 33	Engine Interface
Page 11	Bulk Head Module (BHM) Pin Detail	Page 34	PTO Installation
Page 12	Chassis Module (CHM)	Page 35	PTO Controls
Page 13	Chassis Module (CHM) Pin Detail	Page 36	PTO Air Schematics
Page 14	Multiplexing System Backbone	Page 37	PTO Electrical Schematics
Page 15	System Tap Points	Page 38	Remote Start Stop
Page 16	J1939-250K Gateway	Page 39	VDR Prep Information (NFPA)
Page 17	Low Current Smart Switches	Page 40	SmartPlex VDR Connections
Page 18	High Current Switches (Battery Hot)	Page 41	Snow Plow Lights
Page 19	High Current Switch (BH) Schematics	Page 42	SmartPlex Overview
Page 20	High Current Switches (Ignition Interlocked)	Page 43	SmartPlex Overview Continued
Page 21	High Current Switch (Ignition Interlocked) Schematics	Page 44	SmartPlex Overview Continued
Page 22	High Current Switch Label Options	Page 45	SmartPlex Switch Decoder
Page 23	Body Builder Lighting Interface	Page 46	SmartPlex Schematic
Page 24	Body Builder PDM	Page 47	SmartPlex Schematic

Electrical Component Overview

Body Lighting & Smartplex Interfaces
(Module 35M, 353, 296)

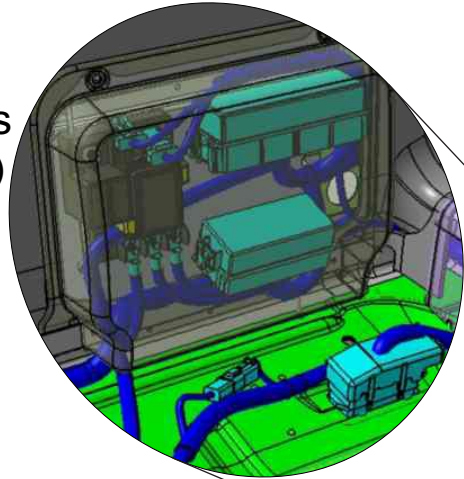

Trailer Interfaces
(Module 296, 297)



Tail Light Configurations
(Module 294)



Accessory Air Valve Assembly (AAVA)
(Module 46E)

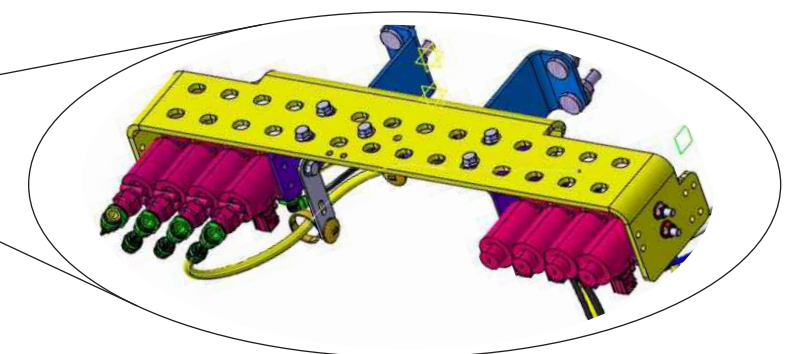

Dash Switches
(Module 329)



Transmission Interfaces
(Grey Plug)
(Plugs may also be frame located
(Module 34C)



Engine Interface
(Black Plug)
(Plugs may also be frame located)
(Module 148, 163, 87L)



Bulk Head Module (BHM)
(Module 32A)



Power Distribution
(Module 285 PDM)



Power Net Distribution Box (PNDB)
(Module 33P/281/293)



Chassis Module
(CHM Under Cab)
(Module 335, 32K)



Electrical Harness Overview

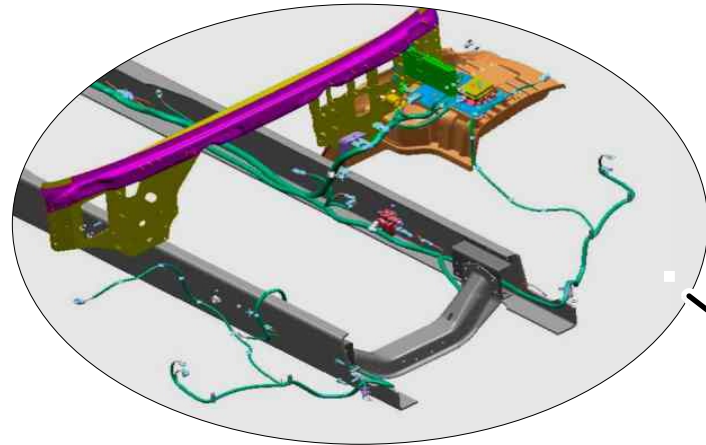

FORWARD CHASSIS HARNESS Module 288
 1) Connections to Bulkhead module and Underhood PDM
 2) Connections to headlamps
 3) Connections to side marker/turn lamps
 4) Connections to Chassis Module

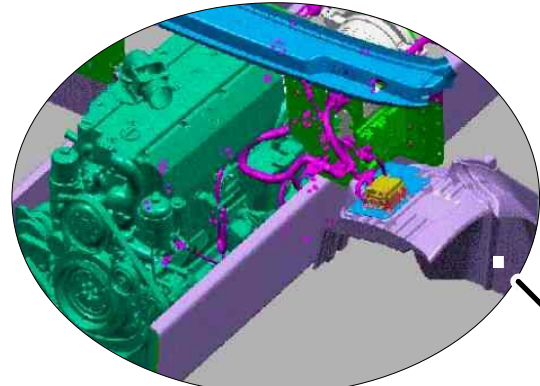

POWERTRAIN HARNESS Module 286, 283
 1) Connections to the Bulkhead Module and Underhood PDM

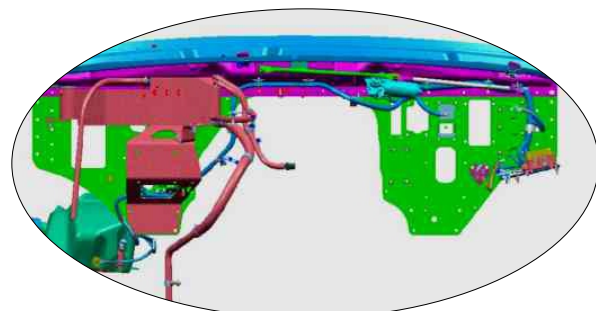

FRONTWALL HARNESS Module 321
 1) Connections to Bulkhead Module and Underhood PDM
 2) Connection to Starter Mag Switch
 3) Connection to Wiper Motor
 4) Connection to the low coolant level sensor and horn (under surge tank)
 5) Connection under cab to Washer pump and level switch
 6) Pass-thru connector to Main Cab Harness and Powertrain Harness

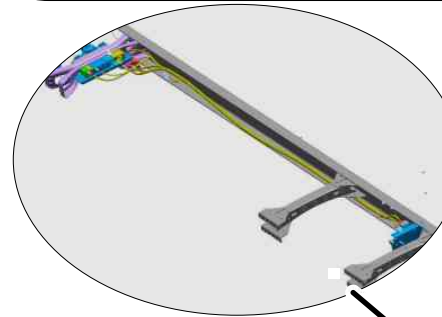

ABS/AMU HARNESS Module 332
 1) Connections to Forward chassis harness and frame ground studs near Chassis module
 2) Connections to AMU (Mod 877 without ABS)
 3) Connections to Wabco ABS ECU
 4) Connections to rear combo valves

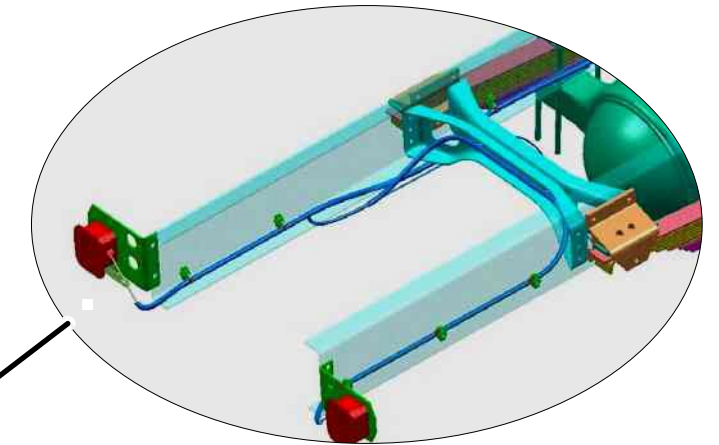

AFT CHASSIS HARNESS Module 28A
 1) Connections to Chassis Module
 2) Connections to tail lamps

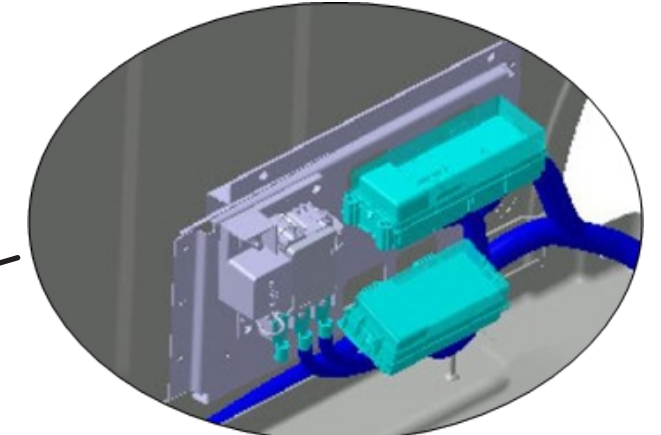

Body Builder and Trailer PDM's Modules 353 and 335
 1) PDM for higher current trailer wiring (and TEM lighting)
 2) PDM for SmartPlex 20A circuits
 3) PNDB for Body power distribution

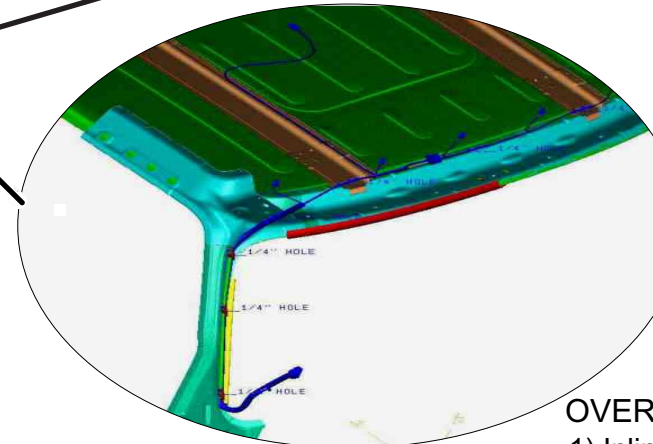

OVERHEAD CAB HARNESS Module 287
 1) Inline connection to Main cab Harness (at bottom of A pillar)
 2) Connections to Marker Lamps
 3) Connections to Dome Lamp

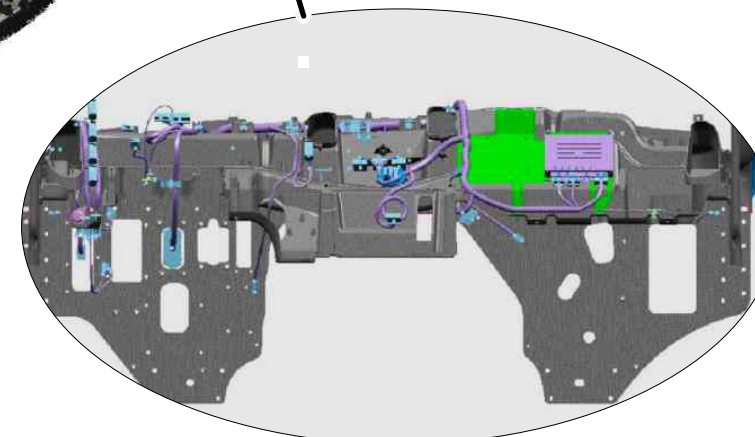

MAIN CAB HARNESS Module 320
 1) Connections to bulkhead connector
 2) Connections to diagnostic connector (behind ignition switch)
 3) Connections to CPC
 4) Pass-thru connector to engine compartment
 5) Gauge Cluster
 6) HVAC unit and controller
 7) Steering wheel horn and windshield wiper

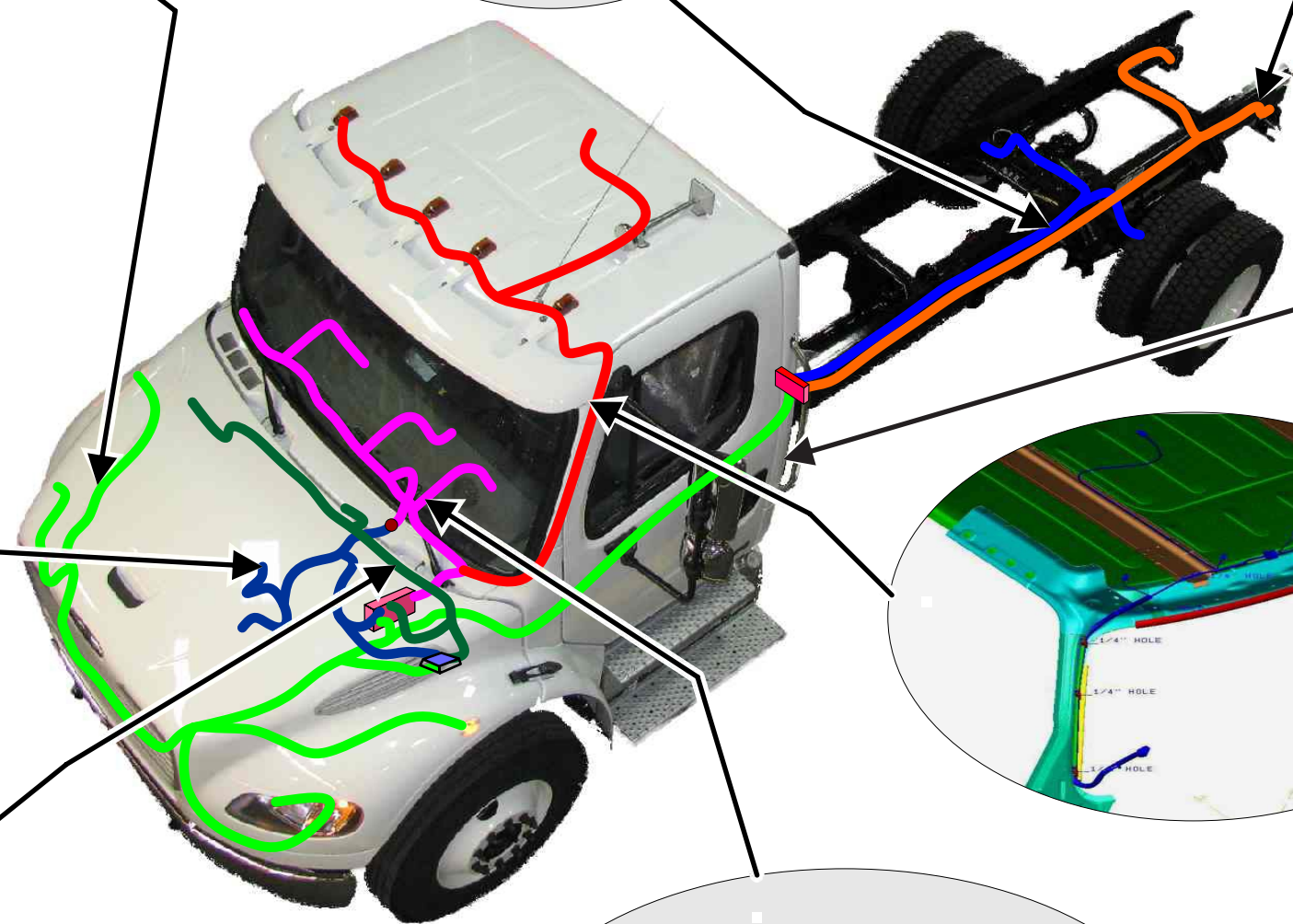

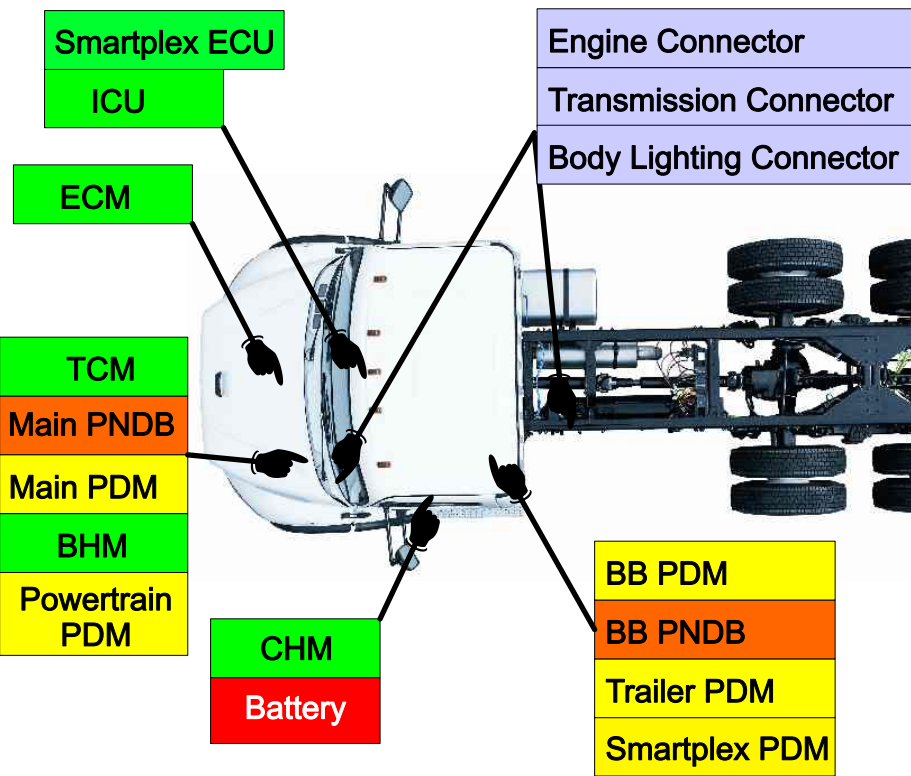

Electrical Power Flow Overview

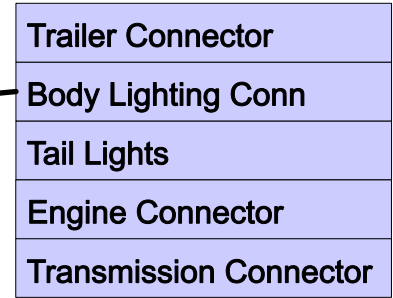

- 32A -Bulkhead Module Outputs**
- B5.F - Cigar Lighter Output
 - B3.E - Horn
 - B5.E - SPARE (Utility Light/Spotlight)
 - B4.M - SPARE (Utility Light/Spotlight)
 - B5.G - SPARE (Ignition)
 - B5.H - Panel Lamps
 - B7.A1 - Panel Lamps (Smart Switch)
 - B4.F - SPARE (Left Heated Mirror)
 - B4.E - SPARE (Right Heated Mirror)
 - B6.A9 - Accessory (HVAC)
 - B6.A10 - Accessory (Radio)
 - B5.A - Battery (Dome Lamps)
 - B7.A12 - Battery (Smart Switch)
 - B6.A8 - Ignition (VCU)
 - B2.K - Ignition (Engine)
 - B1.P - Ignition (ABS)
 - B2.L - Ignition (Trans)
 - B1.F - Fuel Water Sensor Power
 - B5.D - Instrument Cluster
 - B5.B - Dome Lamps Switched
 - B1.L - Left High Beam
 - B1.R - Left Low Beam
 - B5.C - Clearance Lamps
 - B1.K - Tail/License Plate /Trailer Relay
 - B3.F - Wiper High
 - B3.H - Wiper Low
 - B3.G - Washer Pump
 - B2.M - AC Clutch
 - B4.B - Starter Relay (Crank)

- 32K - Chassis Module Outputs**
- C4-D Left Marker Lamp
 - C4-C Left Park Lamp
 - C3-N Turn Left Front/Side
 - C3-R Turn Right Front/Side
 - C3-L Right Low Beam
 - C4-K Right High Beam
 - C3-K Right DRL
 - C4-F Left DRL
 - C3-C Optional Fog/Road Lamps
 - C3-D Optional Fog/Road Lamps
 - C5-H AMU Solenoid #0
 - C5-J AMU Solenoid #1
 - C5-L AMU Solenoid #2
 - C5-M AMU Solenoid #3
 - C3-A Optional Fuel Water Separator Heater
 - C2-F Trailer Marker Relay
 - C2-H Trailer Turn Left Relay
 - C2-E Trailer Turn Right Relay
 - C2-A Trailer Power Relay
 - C2-D Trailer Stop Lamp Relay
 - C4-M Right Marker Lamp
 - C4-L Right Park Lamp
 - C1-P Turn Right Rear
 - C1-G Turn Left Rear
 - C1-H Backup Alarm
 - C1-J Right Backup Lamp
 - C1-A Left Backup Lamp
 - C1-N Left Stop Lamp
 - C1-L Right Stop Lamp
 - C3-P Tail/License Plate Lamp

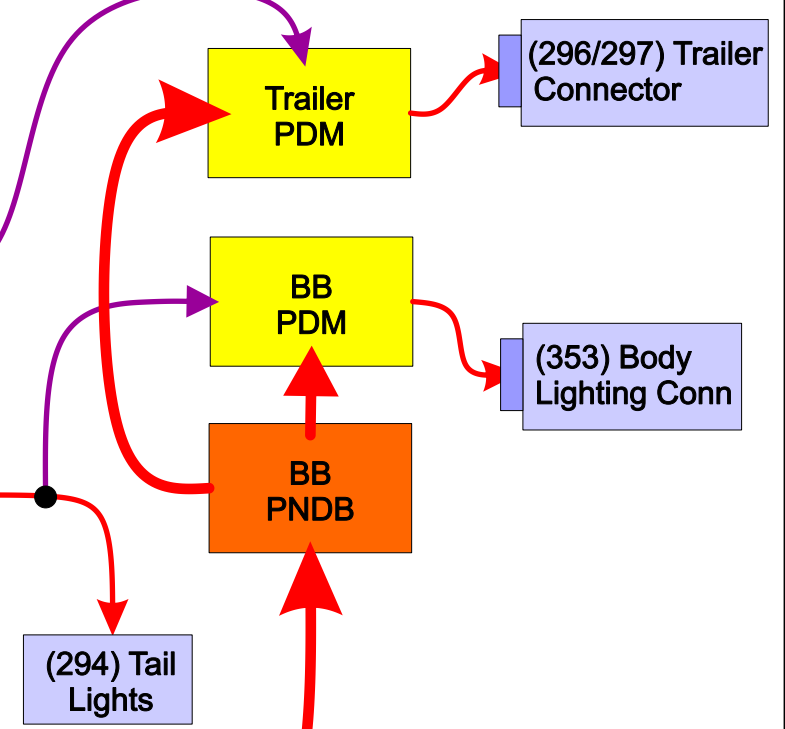
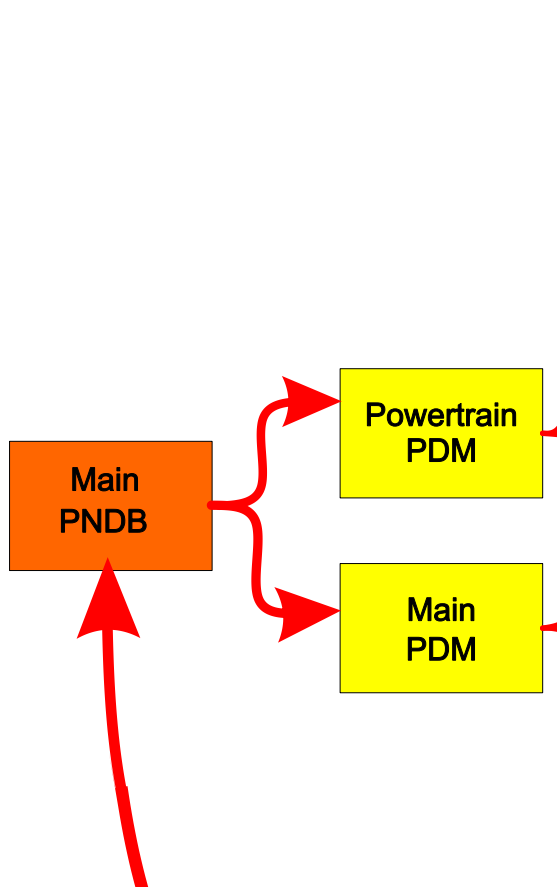
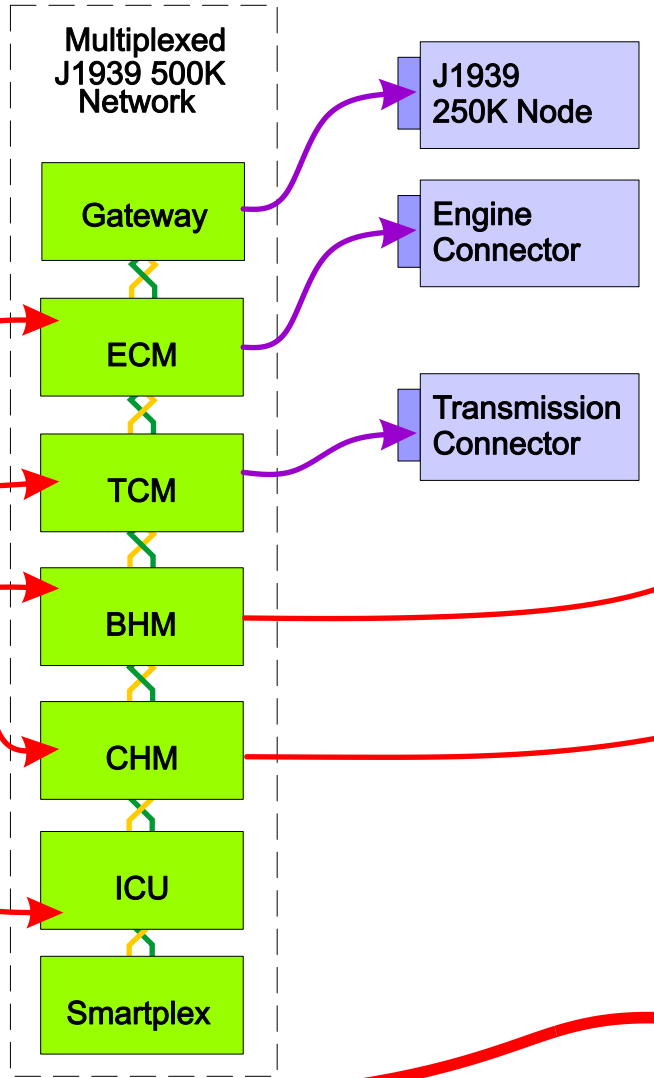

Power Net Distribution Box (PNDB) Mod 33P

The PNDB is a power distribution module designed for the SmartPlex system to deliver more consistent and better protected power from the battery to the other components on the truck.

The PNDB also has protected keep alive circuits that maintain power even when the cutoff switch is in the off position. The primary reason for this change is to provide power to the DEF purge system, which drains urea from the delivery system and prevents the system from freezing during cold conditions.

The PNDB located at the front wall is equipped with three MIDI fuses which supply power to the Main Power Distribution Module. These fuse connections were relocated from the battery box in 2010 to prevent corrosion and improve the trucks reliability in severe conditions.

A secondary PNDB is available as an option for the body builder and is located with the trailer and bodybuilder PDM located in the cab behind the drivers seat on day cabs or under the rear bench seat for crew cab units. Ordered with 33M-001.

PNDB Power Net Distribution Box



INSTALLATION WITH DISCONNECT SWITCH

INSTALLATION WITHOUT DISCONNECT SWITCH

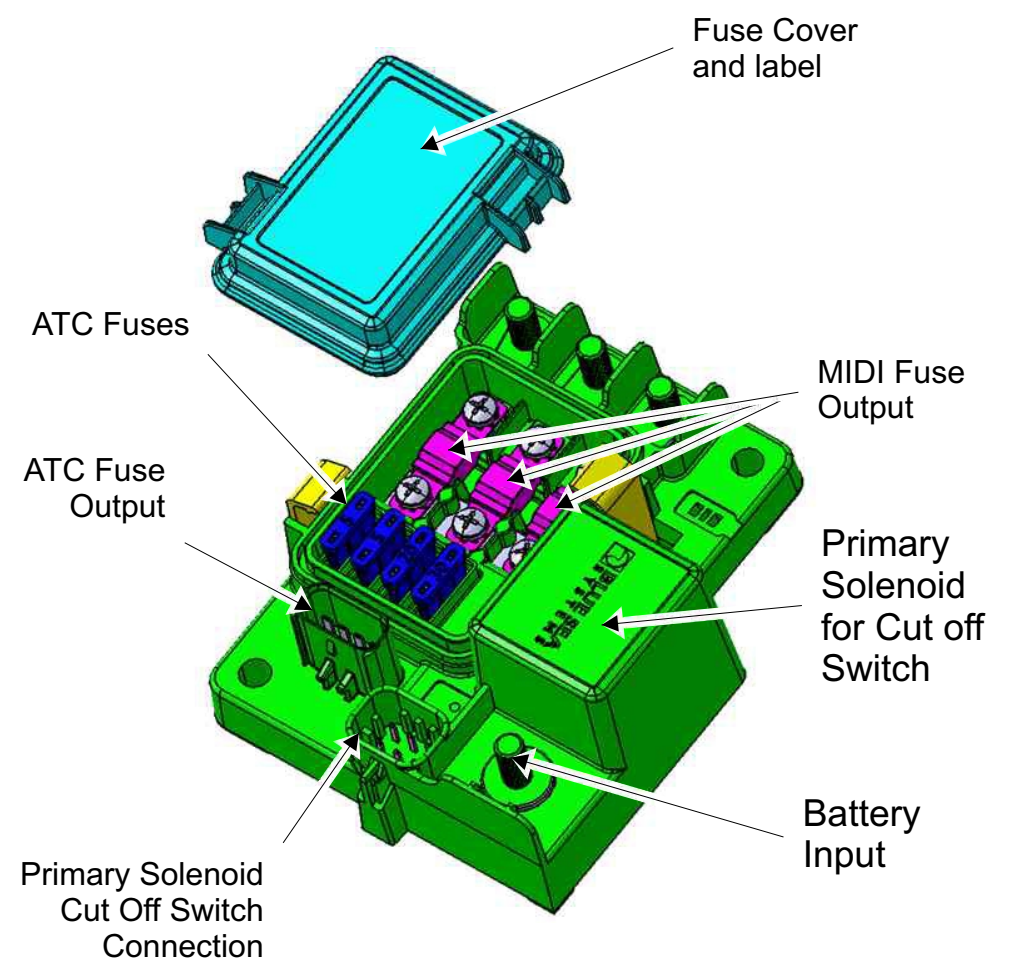

CONNECTOR	PIN	DESCRIPTION
X2 KEEP ALIVE CIRCUIT	1	AFTER TREATMENT ECU
	2	EMERGENCY POWER
	3	RADIO AND CLOCK
	4	ALTERNATOR REMOTE SENSE
X1 SOLENOID CONTROL	A	GROUND
	B	SIGNAL OFF
	C	LED INDICATOR
	D	SIGNAL ON
	E	SIGNAL RETURN
	F	GROUND

Fuse	Description	Function	Rating	Max. Fuse Allowed
ATC-A	Keep Alive Power	After Treatment ECU	30 AMPS	30 AMPS
ATC-B	Keep Alive Power	Emergency Power	20 AMPS	30 AMPS
ATC-C	Keep Alive Power	Radio and Clock	5 AMPS	30 AMPS
ATC-D	Keep Alive Power	Alternator Remote Sense	5 AMPS	30 AMPS
MIDI-1 (Fuse 1)	High AMP Fuse	Powertrain PDM	175 AMPS	200 AMPS
MIDI-2 (Fuse 2)	High AMP Fuse	PDM #2	125 AMPS	200 AMPS
MIDI-3 (Fuse 3)	High AMP Fuse	PDM #1	125 AMPS	200 AMPS

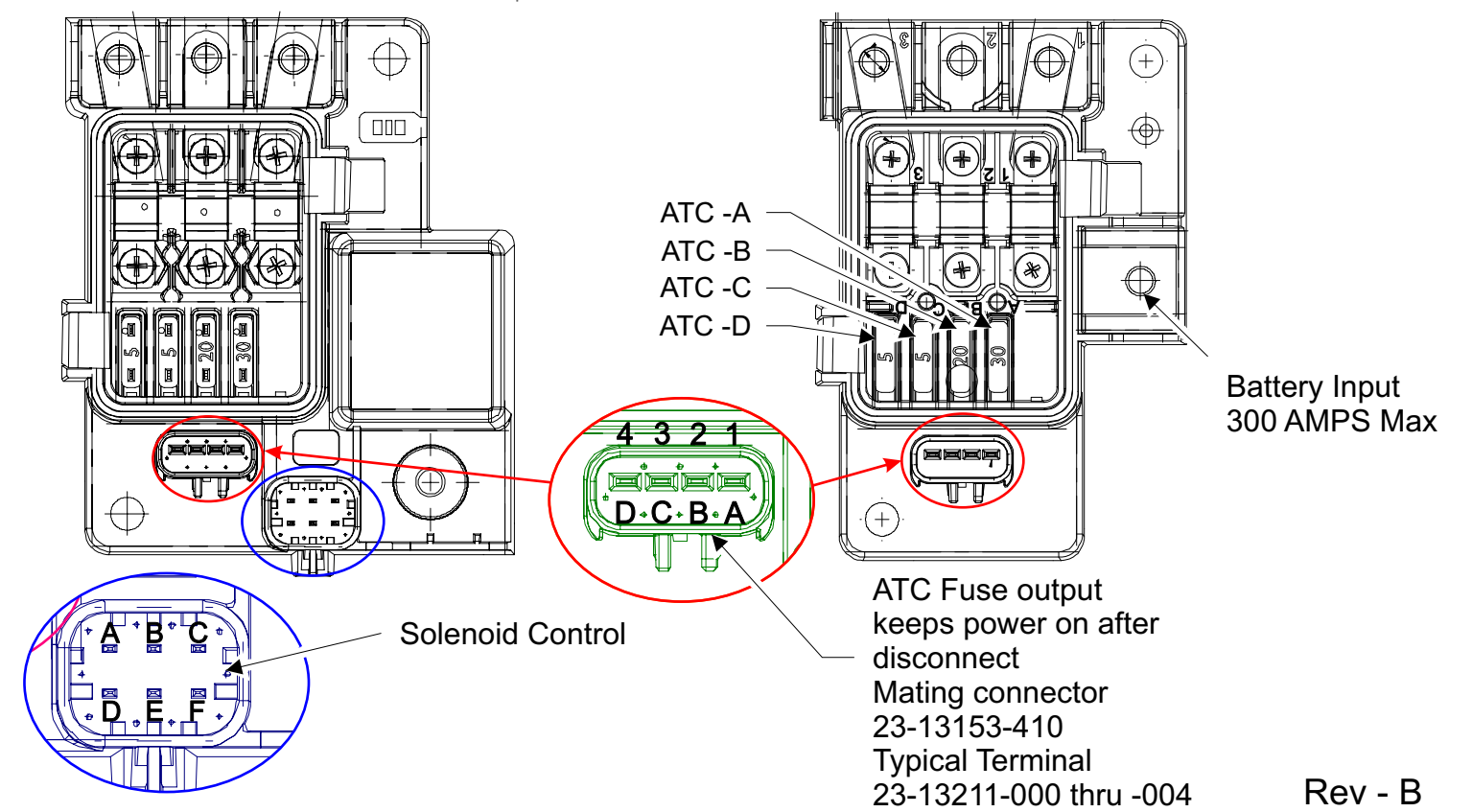

Positive Load Disconnect Switch Mod 293

The disconnect switch system can be ordered as a negative or positive disconnect switch.

In cab disconnect switches are offered in a locking or non locking configuration.

Exterior battery mounted switches are offered in the locking configuration only.

Cutoff switches are equipped with red LED lights, which are illuminated when power is on.

Trucks equipped with the body builder auxiliary power system will have an additional LED light on the switch.

Note: Both PNDB units will be deactivated when the switch is in the off position.

Positive Load Disconnect Switch

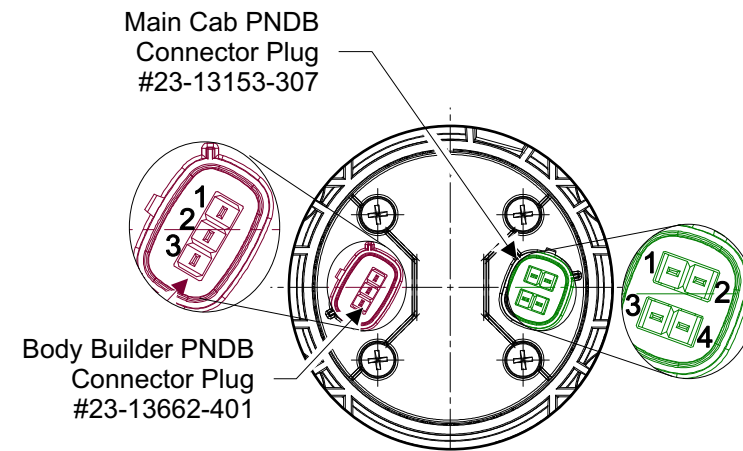

CONNECTOR	PIN	DESCRIPTION
X1, Main PNDB	1	ON SIGNAL
	2	RETURN SIGNAL
	3	LED INDICATOR
	4	OFF SIGNAL
X2, Aux PNDB	1	RETURN SIGNAL
	2	OFF SIGNAL
	3	LED INDICATOR

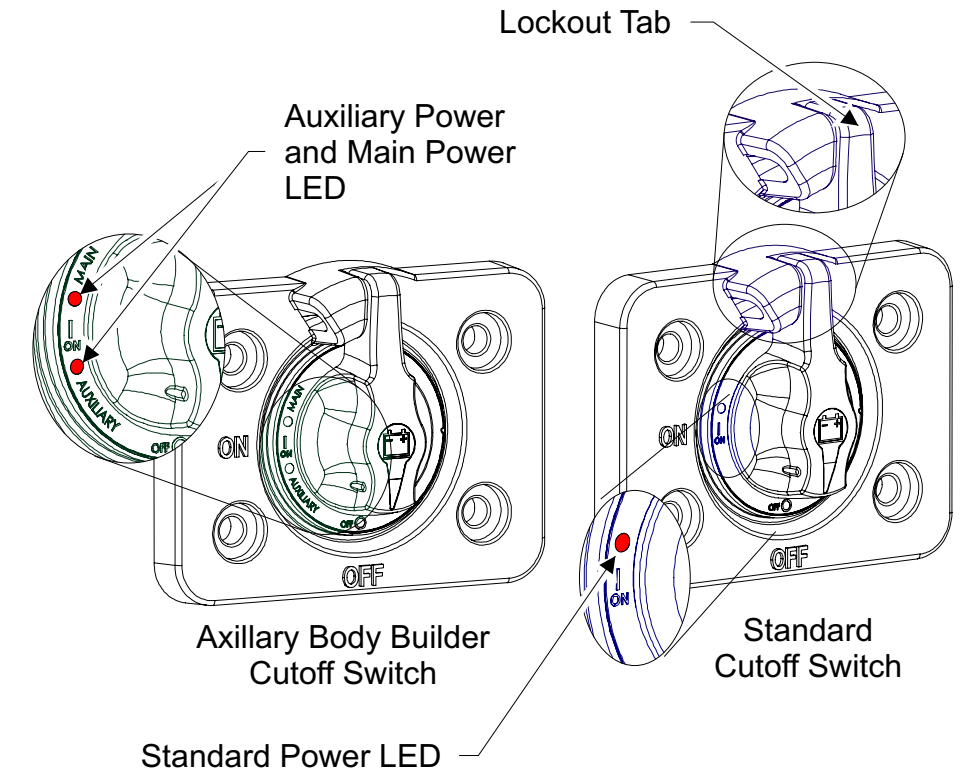

293-058	POSITIVE LOAD DISCONNECT W/CAB MTD CONTROL SWITCH MTD OB DR SEAT
293-060	POSITIVE LOAD DISCONNECT W/CAB MTD CTRL SW W/LOCKING PROV MTD OB DR DEAT
293-061	POSITIVE LOAD DISCONNECT W/BATTERY BOX CTRL SWITCH W/LOCKING PROVISION
293-063	NEGATIVE LOAD DISCONNECT W/BATTERY BOX DISCONNECT SWITCH
293-068	NEGATIVE BATT S/O SW FOR CUM AT BATT BOX W/LOCKING PROV, PARTIAL PDI INST
293-069	NEG BATT S/O SW FOR CUM IN CAB OB DR ST W/LKG PROV, PARTIAL PDI INST



In Cab Mounted Disconnect Switch Mounting
293-058

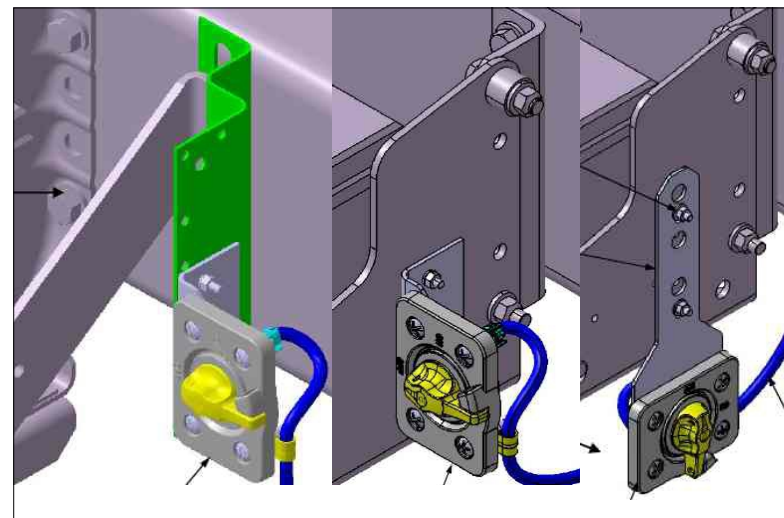

Battery Box Disconnect Switch Mounting with box mounted air tanks (brackets will vary depending on application)
293-061

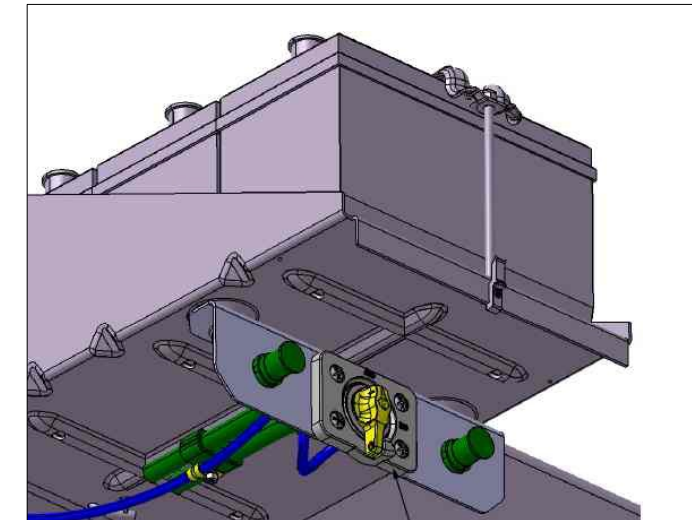

Battery Box Disconnect Switch Mounting without box mounted air tanks
293-061, 293-063



Main Power Distribution Module (PDM) Mod 285

The main Power Distribution Module (PDM) distributes battery power to the various control modules on the vehicle.

The PDM contains mini fuses that protect the power feed circuits to these modules.

For most trucks there will be spare fuse slots available for customers to add additional wiring to the truck after it is purchased.

There are four plugs attaching to the module that supply output connections.

Common spare fuse sockets are listed below but may vary based on the options that have been requested.

Common Spare Fuse locations
F6, F10, F11, F14, F21, F23, F25, F26

Main Power Distribution Module (PDM)

Pin and seal part numbers for harness connection
 23-13213-120 TERM-FEMALE,(20-16) PAC12077411
 23-13213-121 TERM-FEMALE,(14-12) PAC12129493
 23-13213-122 TERM-FEMALE,(10) PAC12077413
 23-12497-000/-002/-019 SEAL,(20-16)
 23-12497-000/-001/-002 SEAL,(14-12)
 23-12497-001 SEAL,(10)

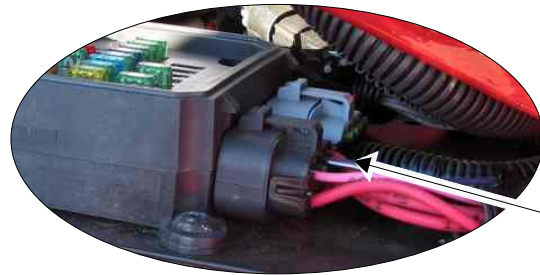

PDM Plugs contain output wires

Power Distribution Module Fuse Specifications*							
Fuse Location	MEGA Fuse	Output Connection	Primary Function	VBAT Fuse	Fuse Rating	Secondary Function	Fuse Rating
F1	1	Green A	Spare		{	{	{
F2	1	Green B	Blower Motor		30A	{	{
F3	2	Green H	Engine ECU		20A	{	30A
F4	2	Green G	Engine ECU		20A	Spare	30A
F5	1	Black D	Ignition Switch		5A	{	{
F6	1	Black C	Spare		{	AUX HVAC	30A
F7	1	Gray F	Bulkhead Module	VBAT 5 BHM	30A	{	{
F8	2	Green C	ICU3-M2		10A	{	{
F9	2	Green D	Trans ECU		30A	{	30A†
F10	2	Blue G Green F	Spare		{	Door Locks/Utility Lamp	10A
F11	2	Blue H	Spare		{	Mirrors	15A
F12	1	Black H	Radio/Diagnostic		20A	{	{
F13	1	Grey E	Chassis Module	VBAT 3 CHM	30A	{	{
F14	1	Black B	Spare		{	LH Power Window	15A
F15	2	Black A	Bulkhead Module	VBAT 4 BHM	30A	{	{
F16	2	Blue A	ABS ECU (pneumatic)		15A	ABS ECU (hydraulic)	25A
F17	2	Blue C	Chassis Module	VBAT 2 CHM	30A	{	{
F18	2	Blue B	Bulkhead Module	VBAT 3 BHM	30A	{	{
F19	2	Grey G	Chassis Module	VBAT 1 CHM	30A	{	{
F20	1	Black E	Bulkhead Module	VBAT 2 BHM	30A	{	{
F21	1	Black F	Spare		{	RH Power Window	15A
F22	1	Black G	Bulkhead Module	VBAT 1 BHM	30A	{	{
F23	1	Grey H Blue E	Spare		{	{	{
F24	1	Grey D	Spare		{	Hydraulic Pump and Motor (hydraulic ABS)	25A
F25	2	Grey C	Spare		{	Optional Switches	30A
F26	2	Grey A Grey B Blue D	Spare		{	{	{

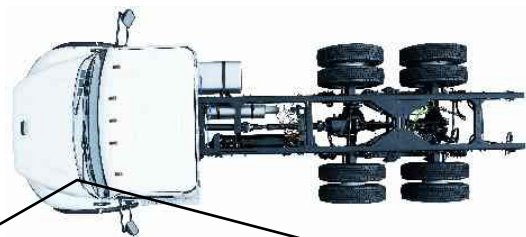

Multiple Wire output
Pin A & B on Grey
Plug and Pin D
on Blue Plug

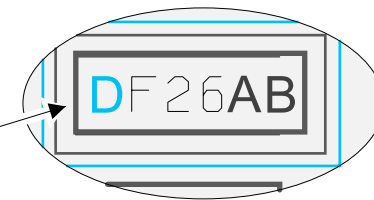

Single Wire Output
found on Green
Plug in Pin G

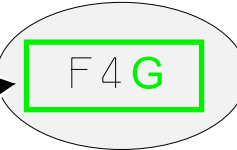

PDM #1
(MIDI-3)

PDM #2
(MIDI-2)

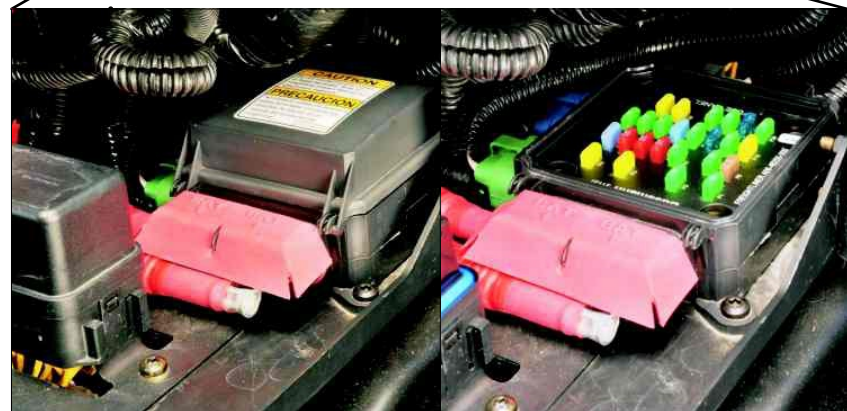
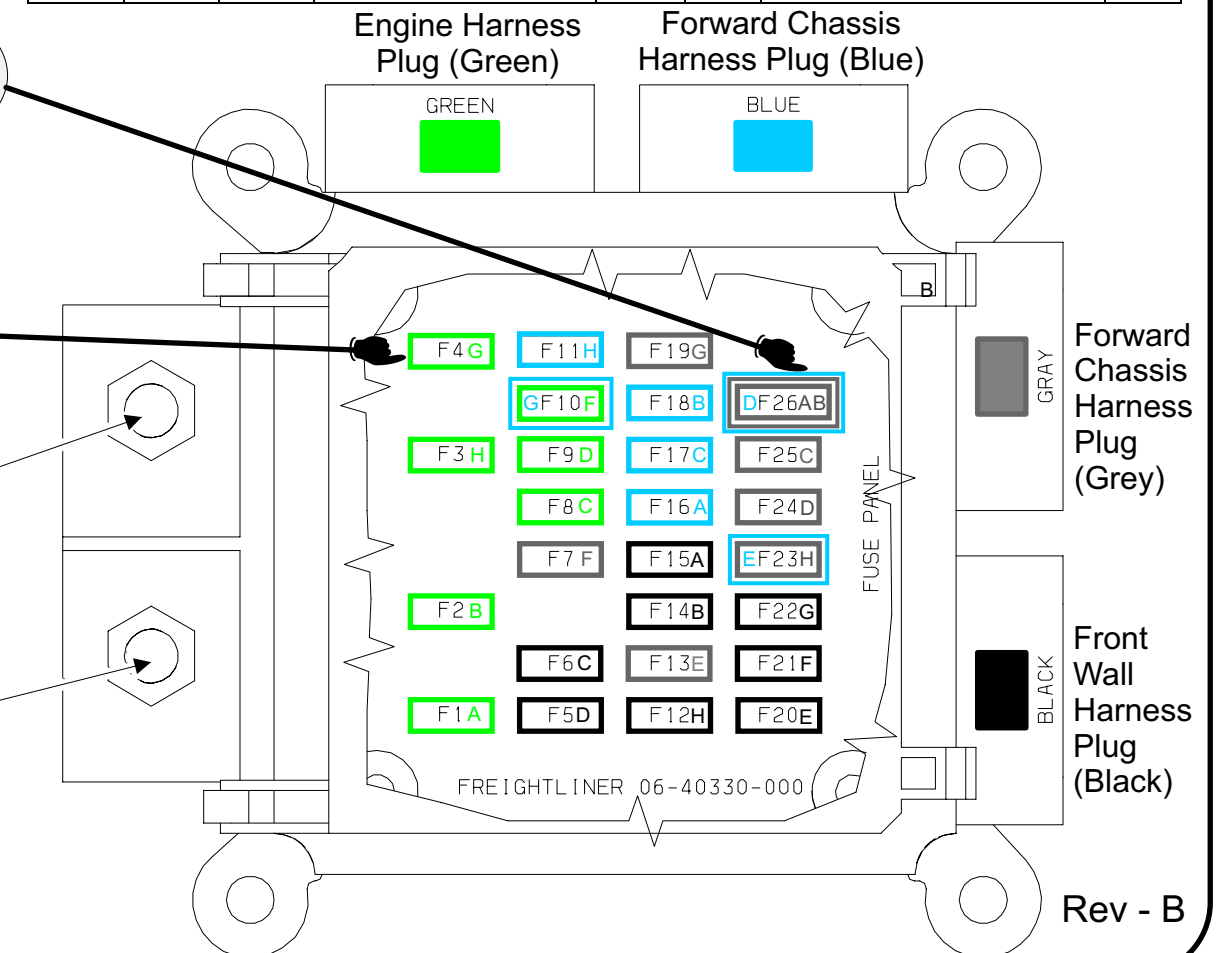



VBAT Fuse System

BHM and CHM output pins are powered by multiple VBAT fuses through the main PDM unit. If one of these fuses is tripped or blown then all pins in the circuit will be affected.

PDM VBAT Fuse Coverage

For this reason seemingly unrelated issues can occur at the same time if a fuse is overloaded and trips.

The lists below show which pins are controlled with the VBAT fuses.

Chassis Module CHM

Power Supply Fuses and Associated Outputs for the Chassis Module				
CHM Power Input	CHM Power Input Pin	Fuse Supplying CHM Power Input	CHM Outputs Supplied	CHM Output Pin
Power In			Power Out	
VBAT1	C4.P	Fuse 19(30A)	Right Low Beam	C3.L
			Turn Right Front/Side	C3.R
			Turn Right Rear	C1.P
			Right Stop Lamp	C1.L
			Left Stop Lamp	C1.N
			Right DRL	C3.K
			Fog/Road Lamps	C3.C/C3.D
			Trailer Turn Right	C2.E
VBAT2	C3.J	Fuse 17(30A)	Left Park Lamp	C4.C
			Right Park Lamp	C4.L
			Left Marker Lamp	C4.D
			Right Marker Lamp	C4.M
			Trailer Marker Relay	C2.F
			Right High Beam	C4.K
			Left Backup Lamp	C1.A
			Right Backup Lamp	C1.J
			Backup Alarm	C1.H
			Turn Left Front/Side	C3.N
Turn Left Rear	C1.G			
VBAT3	C4.J	Fuse 13(30A)	Fuel Water Separator Heater	C3.A
			AAVA Solenoid 0	C5.H
			AAVA Solenoid 1	C5.J
			AAVA Solenoid 2	C5.L
			AAVA Solenoid 3	C5.M
VBAT4	C3.S	Fuse 17(30A)	Common Feed w/ VBAT2	C3.J

Bulkhead Module BHM

Power Supply Fuses and Associated Outputs for the Bulkhead Module				
BHM Power Input	BHM Power Input Pin	Fuse Supplying BHM Power Input	BHM Outputs Supplied	BHM Output Pin
Power In			Power Out	
VBAT1	B3.D	Fuse 22(30A)	Battery (dome lamps)	B5.A
			Battery (smart switches)	B7.A12
			Ignition (VCU)	B6.A8
			Ignition (engine)	B2.K
			Ignition (ABS)	B1.P
			Ignition (trans)	B2.L
			Fuel Water Sensor Power	B1.F
			Dome Lamps Switched	B5.B
			Left Low Beam	B1.R
			A/C Clutch	B2.M
			Smart Switch 1 Indicator	B7.B4
			Smart Switch 2 Indicator	B7.B8
			Smart Switch 3 Indicator	B7.A5
			Smart Switch 4 Indicator	B7.A9
Smart Switch 5 Indicator	B7.B10			
VBAT2	B4.G	Fuse 20(30A)	Accessory (HVAC)	B6.A9
			Accessory (radio)	B6.A10
			Wake Up (instrument cluster)	B5.D
			Left High Beam	B1.L
			Wiper High	B3.F
VBAT3	B1.N	Fuse 18(30A)	Horn	B3.E
			Wiper Low	B3.H
			Spare 8.0 A HSD (ignition)	B5.G
			Panel Lamps	B5.H
VBAT4	B4.K	Fuse 15(30A)	Panel Lamps (smart switch)	B7.A1
			Clearance Lamps	B5.C
			Tail Lamps/License Plate Lamp/Trailer Tail Relay	B1.K
			Washer Pump	B3.G
VBAT5	B1.J	Fuse 7(30A)	12V Output (cigar lighter)	B5.F
			Spare 8.5A (utility light/spotlight)	B5.E/B4.M
			Left Heated Mirror	B4.F
			Right Heated Mirror	B4.E

Rev - B

Bulkhead Module (BHM) Mod 32A

The BHM is the primary command module for the multiplex system.

The BHM controls the operation of the other modules in the system, either directly or indirectly using messages sent over the J1939 network.

The BHM is mounted on the driver side of the front wall and connects to the interior wiring through an opening in the front wall.

The BHM has four harness connections on the engine side of the front wall and three harness connections to the cab interior.

The BHM contains all system parameters and the unit controls power flow and circuit protection to the various components of the multiplex electrical system.

The BHM can also directly support up to 5 smart switches. The BHM is programmable and can be changed and updated by flashing the unit through ServiceLink.

Power supply for the BHM is supplied using VBAT fuses, which reside in the main PDM (see page 8).

The BHM is programmable and the feature screen in ServiceLink can be used to change or add parameters to the BHM.

Bulkhead Module (BHM)

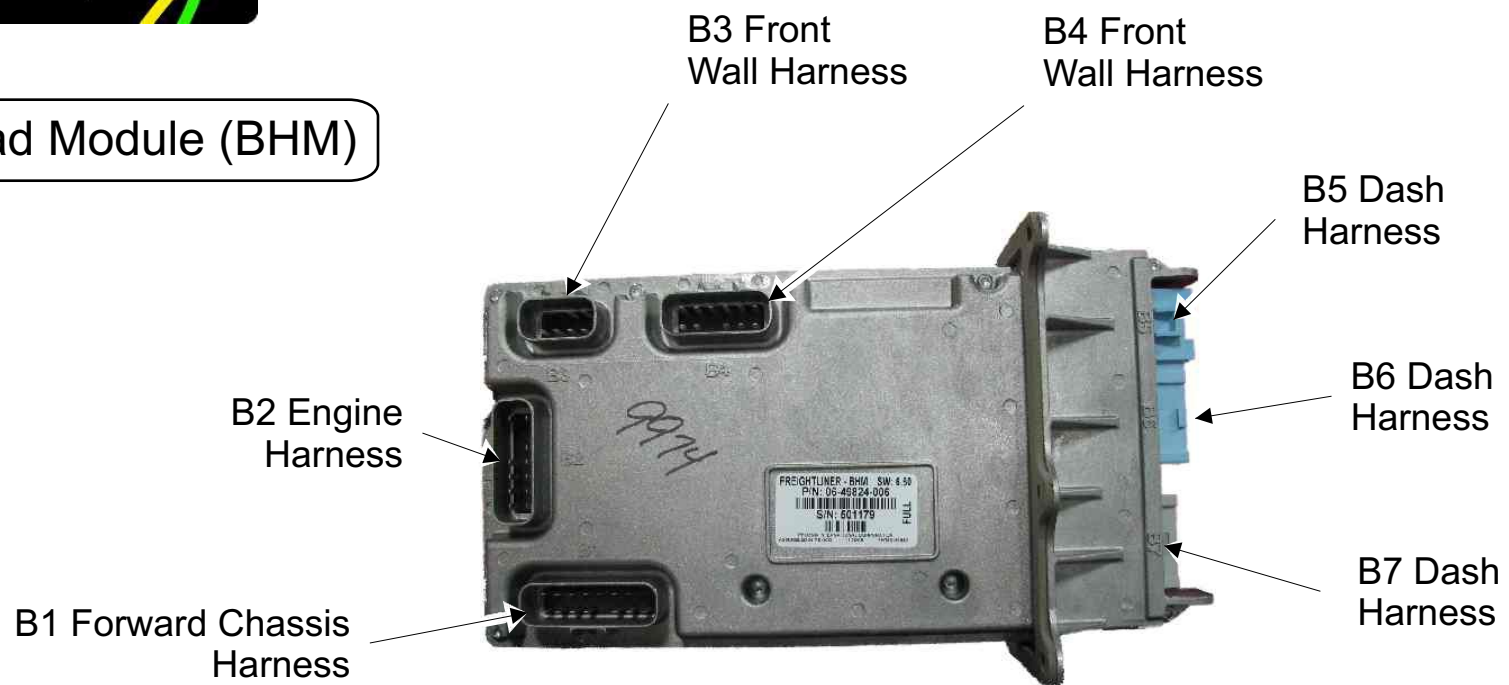

Pin part numbers for harness connection

Outside Cab Connections:
 23-13212-120 TERM-FEMALE,(18-16) PAC153047191
 23-13212-121 TERM-FEMALE,(14-12) PAC15304720
 23-13212-122 TERM-FEMALE,(10) PAC15326004

Inside Cab Connections:
 23-13213-102, PAC12129494 TERM-FEMALE,(12-14)
 23-13213-100, PAC12034046 TERM-FEMALE,(16-18)

Key Bulkhead Module Outputs

- Bulkhead Module outputs have defined amperage limits.
- If higher loads are required, bulkhead module outputs should be used as signal power in conjunction with a relay.

20A	B5.F - Cigar Lighter Output		
12A	B3.E - Horn		
12A	B5.E - SPARE (Utility Light/Spotlight)	Combined	6.7A
Combined	B4.M - SPARE (Utility Light/Spotlight)		
12A	B5.G - SPARE (Ignition)		
12A	B5.H - Panel Lamps	Combined	6.7A
Combined	B7.A1 - Panel Lamps (Smart Switch)		
12A	B4.F - SPARE (Left Heated Mirror)	Combined	6.7A
Combined	B4.E - SPARE (Right Heated Mirror)		
6.7A	B6.A9 - Accessory (HVAC)	Combined	6.7A
Combined	B6.A10 - Accessory (Radio)		
6.7A	B5.A - Battery (Dome Lamps)	Combined	6.7A
Combined	B7.A12 - Battery (Smart Switch)		
		6.7A	Combined
	B6.A8 - Ignition (VCU)		
	B2.K - Ignition (Engine)		
	B1.P - Ignition (ABS)		
	B2.L - Ignition (Trans)		
	B1.F - Fuel Water Sensor Power		
	B5.D - Wake Up (Instrument Cluster)		
	B5.B - Dome Lamps Switched		
	B1.L - Left High Beam		
	B1.R - Left Low Beam		
	B5.C - Clearance Lamps	6.7A	Combined
	B1.K - Tail/License Plate/Trailer Relay		
	B3.F - Wiper High	6.7A	
	B3.H - Wiper Low	6.7A	
	B3.G - Washer Pump	6.7A	
	B2.M - AC Clutch	6.7A	
	B4.B - Starter Relay (Crank)	6.7A	



A B C D
E F G H

B3 Front Wall Harness

Connector B3Frontwall Harness Pinouts		
Connector Pin	Signal Name	Signal Type
B3-A	J1939- 500K Datalink	Datalink
B3-B	J1939+ 500K Datalink	Datalink
B3-C	WiperParkedPosition	DigitalInput
B3-D	MainBatteryPower(VBAT1)	Power
B3-E	Horn	DigitalOutput
B3-F	WiperMotorHighSpeed	DigitalOutput
B3-G	WasherPump	DigitalOutput
B3-H	WiperMotorLowSpeed	DigitalOutput

Bulkhead Module (BHM) Pin Detail

Mod 32A

B4 Front Wall Harness

A B C D E F
G H J K L M

Connector B4 Frontwall Harness Pinouts		
Connector Pin	Signal Name	Signal Type
B4-A	AirFilterRestriction/Spare#9	DigitalInput
B4-B	StarterRelay	DigitalOutput
B4-C	Ground	Ground
B4-D	SpareDigitalInput2	DigitalInput
B4-E	RightHeatedMirror(sparedigitaloutput)	DigitalOutput
B4-F	LeftHeatedMirror(sparedigitaloutput)	DigitalOutput
B4-G	MainBatteryPower(VBAT2)	Power
B4-H	ModuleWake-UpSignal	DigitalInput/Output
B4-J	—	—
B4-K	MainBatteryPower(VBAT4)	Power
B4-L	WasherFluidLevel(sparedigitalinput8)	DigitalInput
B4-M	UtilityLight/Spotlight(sparedigitaloutput)	DigitalOutput



B2 Engine Harness

A B C D E F G
H J K L M N P

Connector B2Engine Harness Pinouts		
Connector Pin	Signal Name	Signal Type
B2-A	J1587+Datalink (not available after Jan 1, 2016)	Datalink
B2-B	J1939+ 500K Datalink	Datalink
B2-C	J1587+ Datalink(not available after Jan 1, 2016)	Datalink
B2-D	J1587- Datalink (not available after Jan 1, 2016)	Datalink
B2-E	—	—
B2-F	—	—
B2-G	BackupSwitch(sparedigitalinput3)	DigitalInput
B2-H	J1587 Datalink (not available after Jan 1, 2016)	Datalink
B2-J	J1939- 500K Datalink	Datalink
B2-K	EngineECUIgnitionPower	DigitalOutput
B2-L	TransmissionECUIgnitionPower	DigitalOutput
B2-M	A/CClutch	DigitalOutput
B2-N	—	—
B2-P	AlternatorCharging	DigitalInput

B5 Dash Harness

A B C D
H G F E

Connector B5 Dash Harness Pinouts		
Connector Pin	Signal Name	Signal Type
B5-A	DomeLampsBattery	DigitalOutput
B5-B	DomeLampsSwitched	DigitalOutput
B5-C	ClearanceLamps(cab)	DigitalOutput
B5-D	InstrumentClusterWake-Up	DigitalOutput
B5-E	UtilityLight/Spotlight(sparedigitaloutput)	DigitalOutput
B5-F	CigarLighter	DigitalOutput
B5-G	IgnitionPower,Other(sparedigitaloutput)	DigitalOutput
B5-H	PanelLamps	DigitalOutput

B7 Dash Harness

Connector B7Dash Harness Pinouts		
Connector Pin	Signal Name	Signal Type
B7-A1	PanelLamps(smartswitch)	DigitalOutput
B7-A2	SmartSwitch3ID1	AnalogInput
B7-A3	SmartSwitch3ID2	AnalogInput
B7-A4	SmartSwitch3Input	AnalogInput
B7-A5	SmartSwitch3Indicator	DigitalOutput
B7-A6	SmartSwitch4ID1	AnalogInput
B7-A7	SmartSwitch4ID2	AnalogInput
B7-A8	SmartSwitch4Input	AnalogInput
B7-A9	SmartSwitch4Indicator	DigitalOutput
B7-A10	SmartSwitch5ID1	AnalogInput
B7-A11	SmartSwitch5ID2	AnalogInput
B7-A12	SmartSwitchBatteryPower	DigitalOutput
B7-B1	SmartSwitch1ID1	AnalogInput
B7-B2	SmartSwitch1ID2	AnalogInput
B7-B3	SmartSwitch1Input	AnalogInput
B7-B4	SmartSwitch1Indicator	DigitalOutput
B7-B5	SmartSwitch2ID1	AnalogInput
B7-B6	SmartSwitch2ID2	AnalogInput
B7-B7	SmartSwitch2Input	AnalogInput
B7-B8	SmartSwitch2Indicator	DigitalOutput
B7-B9	Ground	SignalGround
B7-B10	SmartSwitch5Indicator	DigitalOutput
B7-B11	SmartSwitch5Input	AnalogInput
B7-B12	—	—

B1 B2 B3 B4 B5 B6 B7 B8 B9 B10 B11 B12
A1 A2 A3 A4 A5 A6 A7 A8 A9 A10 A11 A12

B1 Forward Chassis Harness

S R P N M L K J
H G F E D C B A

Connector B1ForwardChassis Harness Pinouts		
Connector Pin	Signal Name	Signal Type
B1-A	—	—
B1-B	ModuleWake-UpSignal	DigitalInput/Output
B1-C	SpareDigitalInput4	DigitalInput
B1-D	—	—
B1-E	Ground	PowerGround
B1-F	Fuel/WaterSensorIgnitionPower	DigitalOutput
B1-G	Ground	SignalGround
B1-H	J1587+ Datalink (not available after Jan 1, 2016)	Datalink
B1-J	BatteryPower(VBAT5)	Power
B1-K	TailLamps/LicensePlateLamp/TrailerTailRelay	DigitalOutput
B1-L	LeftHighBeam	DigitalOutput
B1-M	Fuel/WaterSeparator(sparedigitalinput5)	DigitalInput
B1-N	BatteryPower(VBAT3)	Power
B1-P	ABSIgnitionPower	DigitalOutput
B1-R	LeftLowBeam	DigitalOutput
B1-S	J1587- Datalink (not available after Jan 1, 2016)	Datalink

B6 Dash Harness

B1 B2 B3 B4 B5 B6 B7 B8 B9 B10 B11 B12
A1 A2 A3 A4 A5 A6 A7 A8 A9 A10 A11 A12

Connector B6 Dash Harness Pinouts		
Connector Pin	Signal Name	Signal Type
B6-A1	IgnitionSwitchAccessoryPosition	DigitalInput
B6-A2	ModuleWake-UpSignal	DigitalInput
B6-A3	IgnitionSwitchOn	DigitalInput
B6-A4	—	—
B6-A5	IgnitionSwitchStart	DigitalInput
B6-A6	PassengerDoorOpen(sparedigitalinput10)	DigitalInput
B6-A7	DriverDoorOpen	DigitalInput
B6-A8	VCIgnitionPower	DigitalOutput
B6-A9	HVACPower	DigitalOutput
B6-A10	RadioPower	DigitalOutput
B6-A11	J1587- Datalink (not available after Jan 1, 2016)	Datalink
B6-A12	J1587+ Datalink (not available after Jan 1, 2016)	Datalink
B6-B1	HornSwitch	DigitalInput
B6-B2	TopofClutchSwitch(sparedigitalinput7)	DigitalInput
B6-B3	BottomofClutchSwitch(sparedigitalinput6)	DigitalInput
B6-B4	—	—
B6-B5	PanelLampsIncrease	DigitalInput
B6-B6	PanelLampsDecrease	DigitalInput
B6-B7	A/C ClutchRequest	DigitalInput
B6-B8	HazardSwitch	DigitalInput
B6-B9	HeadlampSwitchPARKPosition	DigitalInput
B6-B10	HeadlampSwitchOnPosition	DigitalInput
B6-B11	HeadlampSwitchOn2Position	DigitalInput
B6-B12	—	—

Chassis Module (CHM) - Module 30K

The Chassis Module (CHM) serves in the multiplex electrical system by acting as a dependant to the Bulkhead Module (BHM).

The CHM responds to commands from the BHM and broadcasts the status of the inputs and outputs that are received, and delivered by the module.

All vehicles are multiplexed and will always come equipped with a Chassis Module.

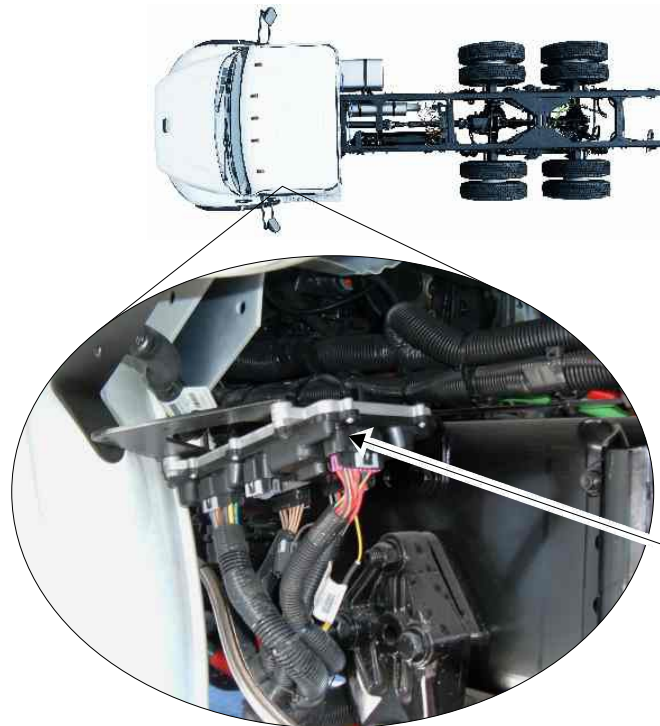

The CHM is under the cab to improve durability and free up frame space

Pin part number for harness connection
 23-13212-120 TERM-FEMALE,(18-16) PAC153047191
 23-13212-121 TERM-FEMALE,(14-12) PAC15304720
 23-13212-121 TERM-FEMALE,(10) PAC15326004

Chassis Module (CHM)



Key Chassis Module Outputs

- Chassis Module outputs have defined amperage limits.
- If higher loads are required, Chassis Module outputs should be used as signal power in conjunction with a relay.

20A	C3-A Optional Fuel Water Separator Heater
10A Combined	C4-C Left Park Lamp
	C4-L Right Park Lamp
	C4-D Left Marker Lamp
	C4-M Right Marker Lamp
7.5A* Combined	C2-F Trailer Marker Relay
	C3-N Turn Left Front/Side
	C1-G Turn Left Rear
	C2-H TrailerTurn Left
7.5A* Combined	C3-R Turn Right Front/Side
	C1-P Turn Right Rear
	C2-E TrailerTurn Right
6.7A Combined	C1-A Left Backup Lamp
	C1-J Right Backup Lamp
	C1-H Backup Alarm

6.7A	C3-L Right Low Beam
6.7A	C4-K Right High Beam
6.7A	C1-N Left Stop Lamp
6.7A	C1-L Right Stop Lamp
6.7A	C3-K Right DRL
6.7A	C4-F Left DRL
6.7A Combined	C3-C Optional Fog/Road Lamps
	C3-D Optional Fog/Road Lamps
0.85A	C5-H AMU Solenoid #0
0.85A	C5-J AMU Solenoid #1
0.85A	C5-L AMU Solenoid #2
0.85A	C5-M AMU Solenoid #3
0.2A	C2-A Trailer Power Relay

A B C D E F G
H J K L M N P

C1 Tail Light Harness

Taillight Harness Pinouts at Connector C1				
Connector and Pin Numbers	Signal Name	Signal Type	Full	Standard
C1-A	LeftBackupLamp	DigitalOutput	X	X
C1-D	LeftTaillightPass-through	Pass-through	X	X
C1-E	RightTaillightPass-through	Pass-through	X	X
C1-F	LicensePlateLamp	DigitalOutput	X	X
C1-G	LeftRearTurnLamp	DigitalOutput	X	X
C1-H	BackupAlarm	DigitalOutput	X	X
C1-J	RightBackupLamp	DigitalOutput	X	X
C1-L	RightStopLamp	DigitalOutput	X	X
C1-N	LeftStopLamp	DigitalOutput	X	X
C1-P	RightRearTurnLamp	DigitalOutput	X	X

Chassis Module (CHM) Pin Detail

Mod 32K



H G F E D C B A
J K L M N P R S

C2 Trailer Module Harness

A B C D
E F G H

Trailer Module Harness Pinouts at Connector C2				
Connector and Pin Numbers	Signal Name	Signal Type	Full	Standard
C2-A	Trailer Power Relay	Digital Output	X	
C2-C	Ground	Power Ground	X	
C2-D	Trailer Stop Lamp Relay Pass-through	Pass-through	X	
C2-E	Trailer Right Turn Lamp	Digital Output	X	
C2-F	Trailer Marker Lamps Relay	Digital Output	X	
C2-G	Trailer Taillight Relay Pass-through	Pass-through	X	
C2-H	Trailer Left Turn Lamp	Digital Output	X	

C3 Forward Chassis Harness

Forward Chassis Harness Pinouts at Connector C3				
Connector and Pin Numbers	Signal Name	Signal Type	Full	Standard
C3-A	Fuel/Water Separator Heater	Digital Output	X	
C3-B	J1587-Datalink (not available after Jan 2016)	Datalink	X	X
C3-C	Fog/RoadLamps	Digital Output	X	
C3-D	Fog/RoadLamps	Digital Output	X	
C3-E	Low Air Pressure	Digital Input (active low)	X	X
C3-F	Park Brake	Digital Input (active low)	X	X
C3-G	ServiceBrake	DigitalInput(active low)	X	X
C3-H	Ground	PowerGround	X	X
C3-J	MainBatteryPower(VBAT2)	Power	X	X
C3-K	RightDRL	DigitalOutput	X	
C3-L	RightLowBeam	DigitalOutput	X	X
C3-M	Ignition	DigitalInput(active high)	X	X
C3-N	LeftFront/SideTurnLamp	Digital Output	X	X
C3-P	Taillight/LicensePlateLampsPass-through	Pass-through	X	X
C3-R	RightFront/SideTurnLamp	DigitalOutput	X	X
C3-S	J1587+Datalink (not available after Jan 2016)	Datalink	X	X

C5 Air Management Unit

M L K J H G
F E D C B A

Connector C5Air Management Unit (AMU)Harness Pinouts				
Connector and Pin Numbers	Signal Name	Signal Type	Full	Standard
C5-A	AMUAnalogInput0	DigitalInput(activelow),AnalogInput	X	
C5-B	AMUAnalogInput1	DigitalInput(activelow),AnalogInput	X	
C5-C	Ground	SignalGround	X	
C5-F	AMUAnalogInput2	DigitalInput(activelow),AnalogInput	X	
C5-G	AMUAnalogInput3	DigitalInput(activelow),AnalogInput	X	
C5-H	AMUSolenoid0	DigitalOutput	X	
C5-J	AMUSolenoid1	DigitalOutput	X	
C5-L	AMUSolenoid2	DigitalOutput	X	
C5-M	AMUSolenoid3	DigitalOutput	X	

C4 Forward Chassis Harness

S R P N M L K J
H G F E D C B A

ForwardChassis Harness Pinouts atConnector C4				
Connector and Pin Numbers	Signal Name	Signal Type	Full	Standard
C4-A	ModuleWake-upSignal	DigitalInput/Output	X	X
C4-B	AddressIdentificationA	AnalogInput	X	X
C4-C	LeftParkLamp	DigitalOutput	X	X
C4-D	LeftMarkerLamp	DigitalOutput	X	X
C4-E	AddressIdentificationC	AnalogInput	X	X
C4-F	LeftDRL	DigitalOutput	X	
C4-G	J1939+ 500K Datalink	Datalink	X	X
C4-H	Ground(addressidentificationD)	SignalGround	X	X
C4-J	MainBatteryPower(VBAT3)	Power	X	
C4-K	RightHighBeam	DigitalOutput	X	X
C4-L	RightParkLamp	DigitalOutput	X	X
C4-M	RightMarkerLamp	DigitalOutput	X	X
C4-N	AddressIdentificationB	AnalogInput	X	X
C4-P	MainBatteryPower(VBAT1)	Power	X	X
C4-R	J1939- 500K Datalink	Datalink	X	X
C4-S	Ground	PowerGround	X	X

Multiplexing System - Mod 160

The term "multiplexing" describes how the SmartPlex electrical system works.

Multiplexing is defined as the process of sending multiple electronic messages through the same signal path at the same time - in this case, through the data link.

The system communicates using two primary forms of communication called data links: J1939-500K datalink (High speed) and the J1939-250K datalink (low speed).

J1939-500K

(White w/ yellow stripe J1939+ ; White w/ green stripe J1939- ; In a twisted pair)

- A high speed vehicle communications network, which permits devices to broadcast requests as well as receive information from all other devices on the network.
- Each message includes an identifier much like a CB channel setting that defines the message priority, who sent it, and what data is contained within it.
- A terminating resistor is installed at each end of the network to dampen feedback signals.

J1939-250K (Yellow J1939+ ; Green J1939- ; In a twisted pair)

- This databus information is available through the use of a standard gateway (mod 835).
- **This is the recommended interface databus for all aftermarket/TEM devices.**

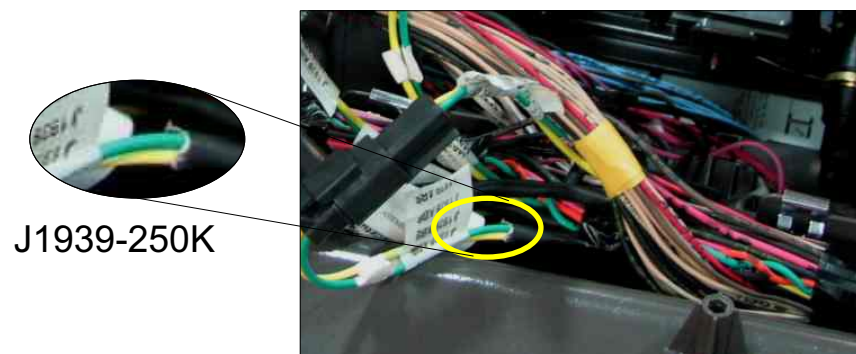

J1939-250K

Multiplexing System Backbone

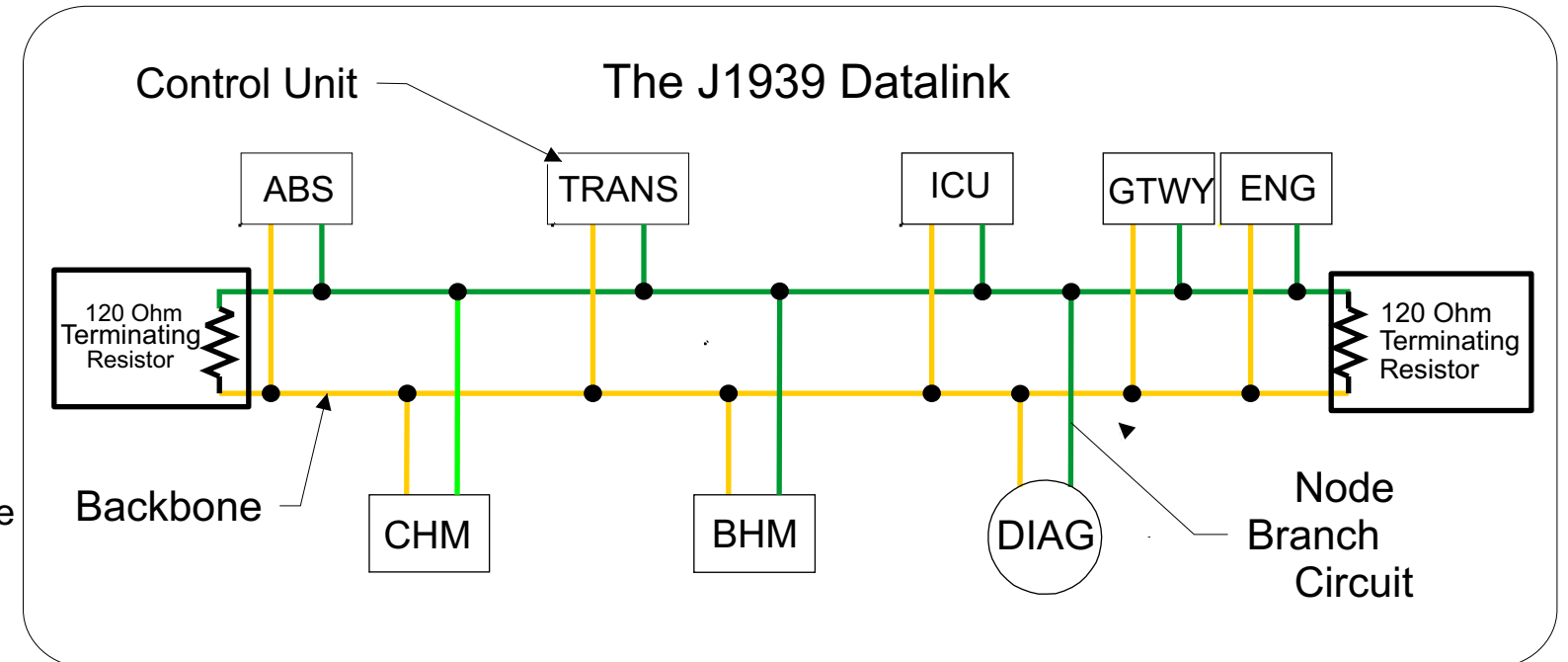

System Terminology

J1939 Backbone - The main J1939 datalink wiring that lies between the two terminating resistors. It does not include the branch nodes to each ECU or to the diagnostic connector.

* Minimum length between any 2 nodes = 10 cm

* Maximum branch length = 3 meter

* Maximum total network length = 40 meters

Node Branch Circuit - The section of J1939 datalink between the backbone and each control unit that has J1939, and between the backbone and the diagnostic connector.

Diagnostic Connector - a 9-pin diagnostic connector is used for troubleshooting the electrical system. It can be found under the dash on the driver side, outboard of the steering column.

Control Unit - connects to the J1939 datalink via a branch circuit (Node).

NODE - A node is the connection point for a device or control unit. See "System Tap Points" for more information on adding nodes to the backbone.

Gateway - A gateway is a conversion device that translates information from J1939-500K into J1939-250K signals.

M2 J1939-500K Nodes			
Option Node	Status	Option Node	Status
Engine	Standard	Trans	Optional
Cluster	Standard	Allison Shifter	Optional
ABS	Standard		
BHM	Standard		
CHM	Standard		
Gateway	Standard		

M2 J1939-250K Node	
Option Node	Status
Body Builder	Standard
Telematics	Optional
Qualcom	Optional

Dash Tap Points

Ignition Power, Ground and Dash Illumination

Tapping into dash illumination and ignition power and ground can be accomplished by using the center tap point connections located in the center back wall of the dash.

Note:

- * Ignition power source will be powered during engine cranking
- * Ignition power source will not be powered when key is in accessory position.

J1939-250K Connections

Tying into the J1939-250K backbone is accomplished by tapping into the system at any of the three dash splice packs (LH, RH, and Center of dash).

The cab terminating resistor is located in the dash on the driver side. It should be close to the splice pack interface node. The second resistor is integrated with the gateway.

The correct datalink resistance measured at any device, or at the diagnostic plug should be 60 ohms with the battery disconnected.

IMPORTANT:

- It is essential that the terminating resistor remain connected to the end of the J1939-250K backbone to dampen feedback signals. Numerous J1939 problems can be attributed to terminating resistors missing or being disconnected.

- If connections under dash become disconnected. Connections should never be reconnected back together directly IE ABS with ABS as this creates an independent circuit in the system that is not connected to the backbone.



J1939-250K Connections for Body Builders

To connect easily to J1939-250K in the dash order the following parts:

- (2) Terminals FTL# 23-13213-142 (supplier: PAC12110843)

Component Module Locations	
Component	Module Number
General J1939 harness drawings, schematics, and installation drawings	160
Engine harness, installation drawings and wiring diagrams	283 and 286
Transmission harness, installation drawings and wiring diagrams	34A, 34B and 343
ABS harness and installation drawings	330, 332, and 333
Gateway harness and installation drawings	860 and 835
General dash wiring (IGN/ILLUM)	320

System Tap Points

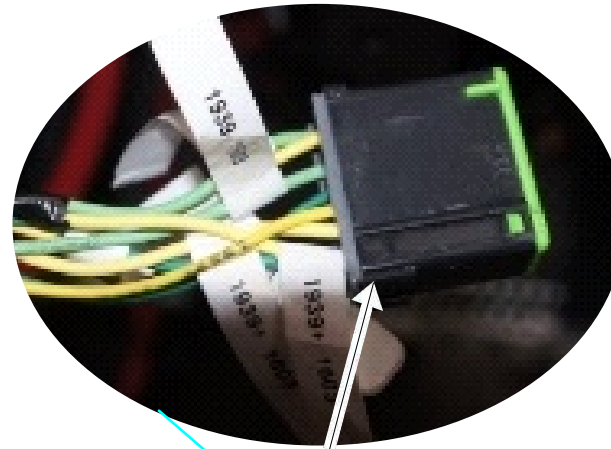

J1939-250K connection is used for TEM interfacing or adding additional devices such as telematics modules.
3 locations: Passenger side dash.
Center of dash.
Driver side dash.

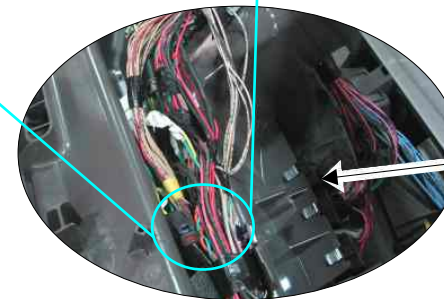

Dash Tap point

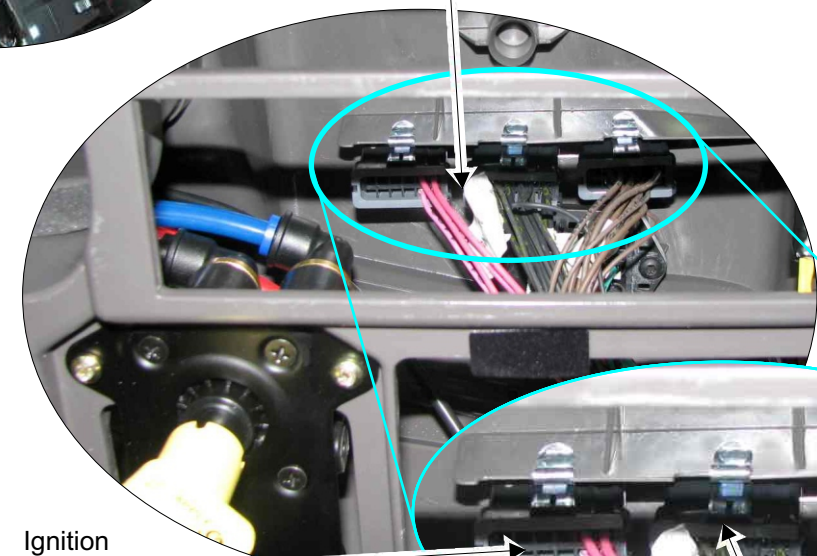

Illumination Circuit 29A
Max load: 5amps

Ignition Circuit 81C
Max load: 5amps

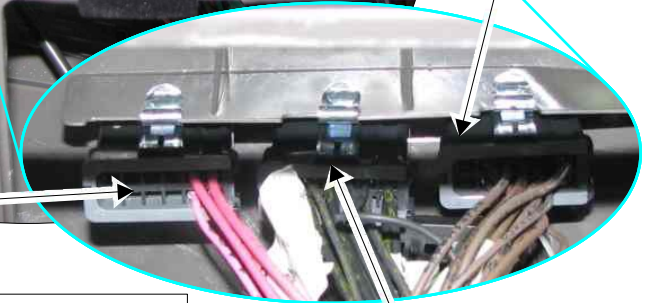

Ground Circuit GND
Max load: 10amps

Pin part number for harness connection
TERM-FEMALE,(18-16) PAC12110844
TERM-FEMALE,(14-12) PAC12110842

Dash Tap Points

Cab resistor Resistor Receptor
Part FTL# 23-13303-902
Deutsch # DTM04 - 2P - EP10

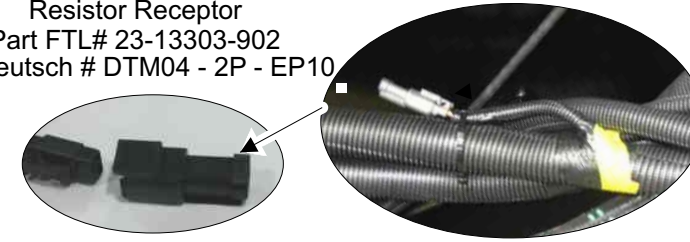

EOL resistor located in gateway module

The J1939-250K Datalink

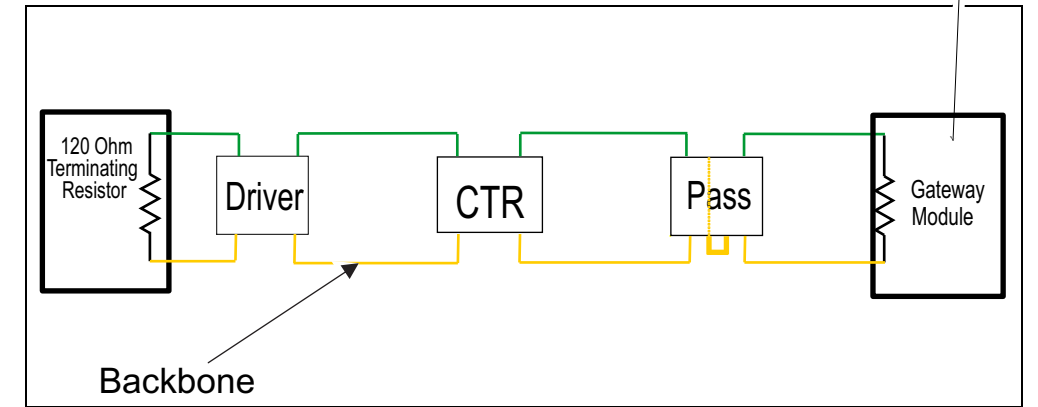

J1939-250K Multiplexing System connections

J1939-250K Gateway Communications

Standard: 835-003 - J1939 500KBPS to J1939 250KBPS gateway

J1939-250K Gateway
Mod 160, 835

- On OBD2016 and forward engines, manufacturers will no longer provide J1708/J1587 data bus and the system will be supported using one single communication system data bus – J1939 .

Third Party Connections

- Third party systems can be connected at any of the three factory provided splice packs (160-038). There is also the option to order the vehicle with just an old style 9-pin in the center of the dash via data code 160-039.

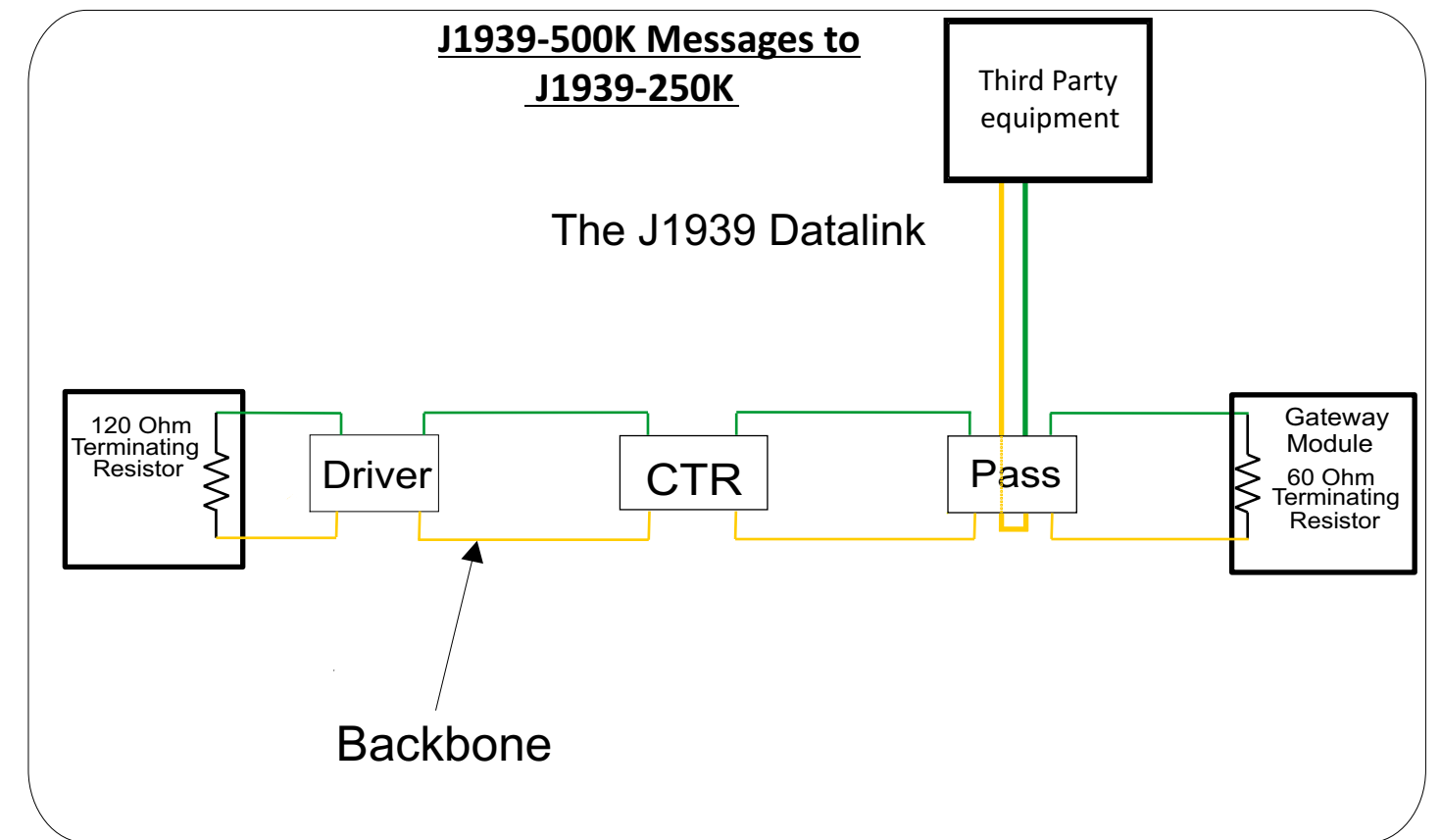
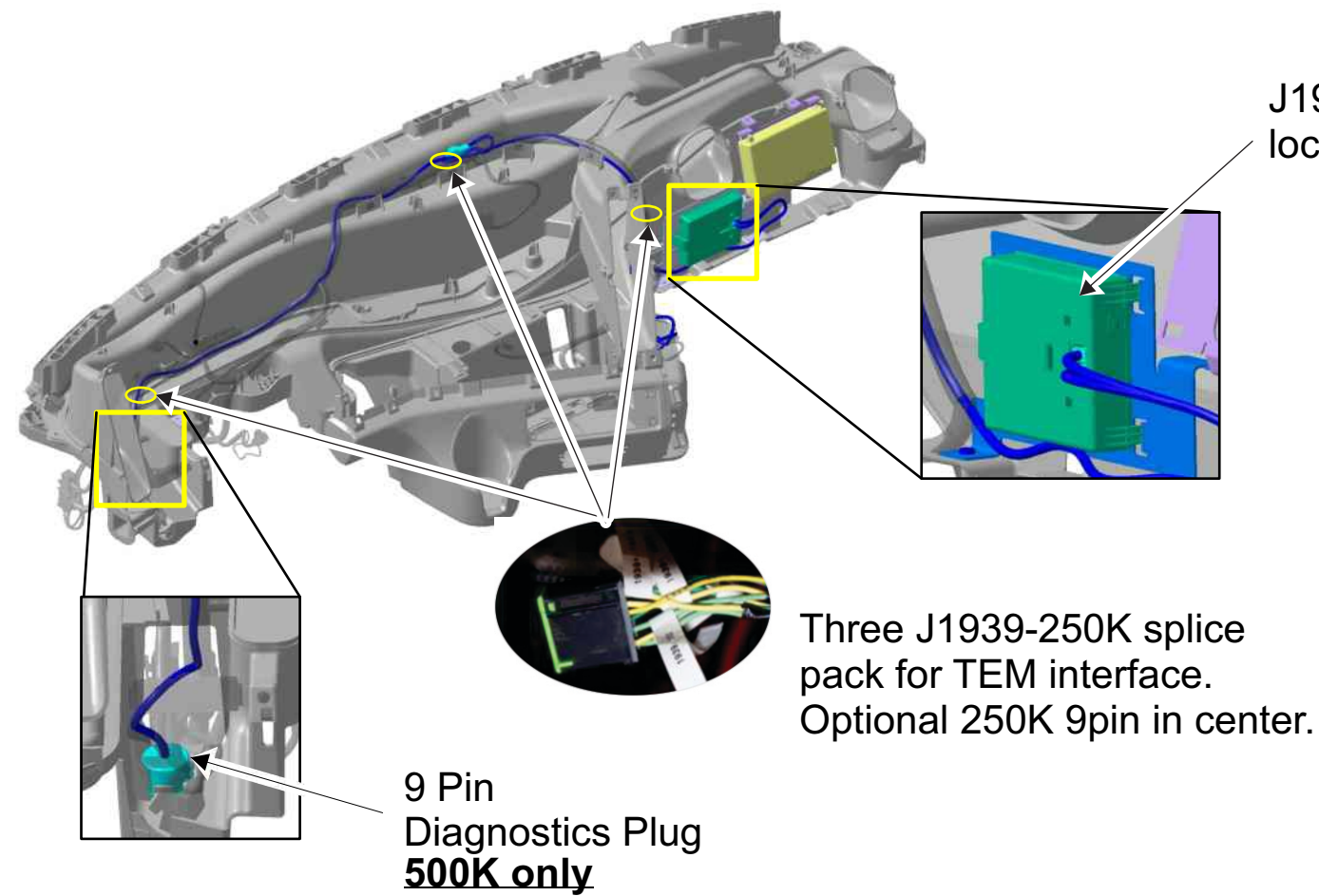
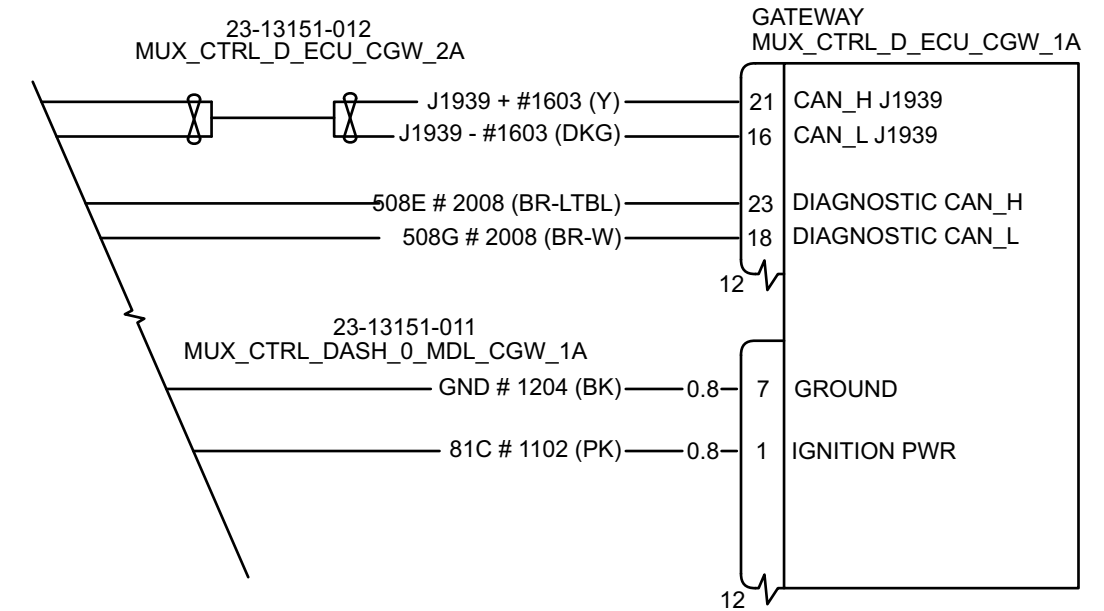

Low Current Smart Switches

Smart switches are low current switches that use signals to communicate with the BHM to tell what function they effect and what state they are in (on or off etc.).

There are two primary types of Smart Switch

1. A two position switch supplies an on or off signal to the BHM.
2. A three position switch allows for an up/down/off signal to the BHM.

Smart switches identify themselves by two voltage signals to the bulkhead module.
(Used in applications where more than one input is required.)

Each switch has a unique combination of resistors that control the voltage signal to the BHM allowing it to identify the switch.

Each channel can talk independently to the Bulkhead module at the same time.

In order for a smart switch to work on the vehicle the BHM must be programmed to hear it, this is done through the features screen using ServiceLink.

Accessing the features screen can be accomplished on-site at the body builder if they are set up with ServiceLink.

Three common faults can occur with Smart Switches

1. Extra Smart Switch fault - indicates that a smart switch has been installed that the vehicle is not programmed to utilize.
2. Duplicate Smart Switch fault - indicates that there are two or more identical smart switches connected to either the BHM or SEM smart switch ports. To fix this error the duplicate smart switches must be removed from the system.
3. Missing Smart Switch fault - indicates that a smart switch has been programmed but is not installed.

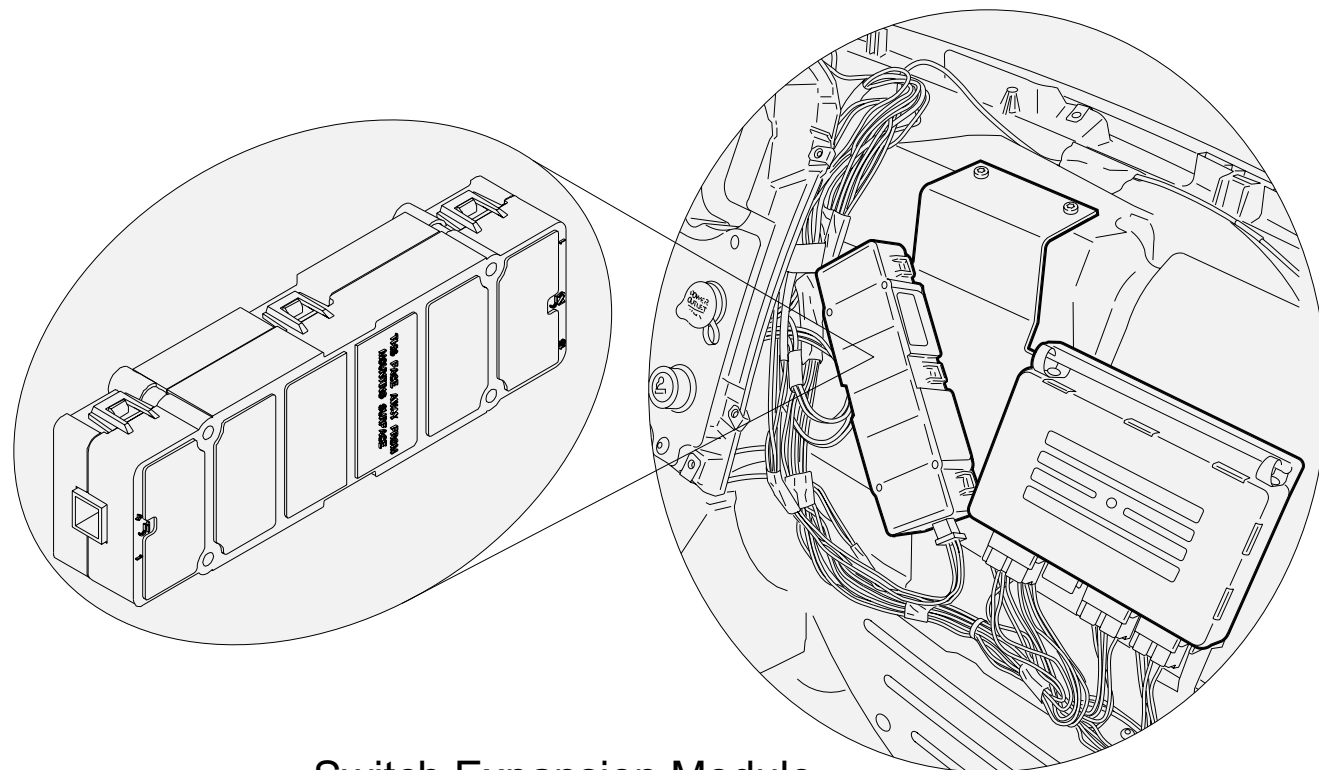

Switch Expansion Module

Low Current Smart Switches

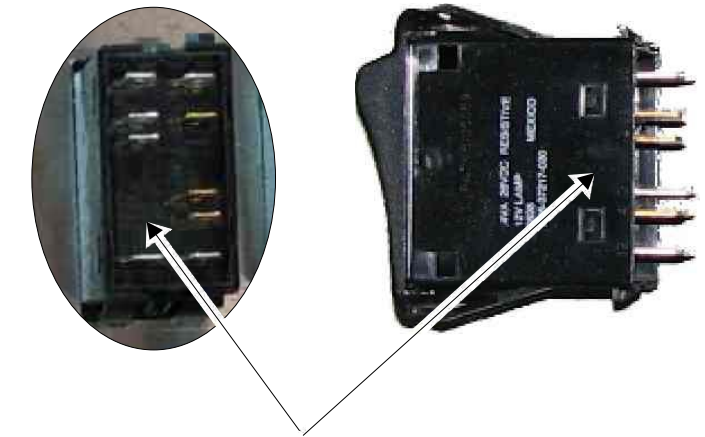

Low Current Smart Switch

Easily identified by the Black backing on the switch

860-004 SMART SWITCH EXPANSION MODULE (SEM)

A Switch Expansion Module (SEM) is available for the vehicle when more than five smart switches are installed on the vehicle. Each adds up to 6 smart switches (beyond the standard 5 supported directly by BHM).

The function of the SEM is to; read all of the smart switch Id's and positions; transmit the smart switch IDs and position data on the J1939 datalink; turn on the smart switch indicator lights when commanded to do so by the Bulkhead Module (BHM).

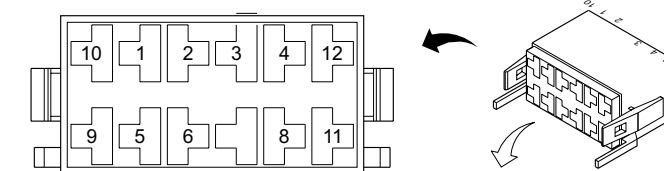

Smart Switch Pinout for a Two Position Switch Pins

Pin	Circuit Number	Circuit Description
2	474B	Switch Position Input
7	474C	Switch Function ID 1 Input
8	474D	Switch Function ID 2 Input
9	GND	Ground
10	14E	Indicator (+)
11	29A	Backlighting (+)
12	474A	Indicator (I)

Smart Switch Pinout for a Three Position Switch Pins

Pin	Circuit Number	Circuit Description
2	474B	Switch Position Input
7	474C	Switch Function ID 1 Input
8	474D	Switch Function ID 2 Input
9	GND	Ground
11	29A	Backlighting (+)

Low Current Smart Switch Socket

High current Switch (Battery Hot)

- Optional battery hot power switches are factory-installed, switch controlled power provisions that can be ordered for a SmartPlex vehicle.
- Optional switches can be ordered in various switch configurations as shown below.
- All optional high current switches mount on the dash, provide fuse protected battery power, and route to a customer access point ending in blunt cut wires.
- Optional switches are commonly used to provide battery-powered lighting, such as dome, spot, or beacon lights. Other applications include using the optional switch as a triggering mechanism to enable other features, such as hydraulic lift operations or access panel locks.

High Current Switches (Battery Hot)

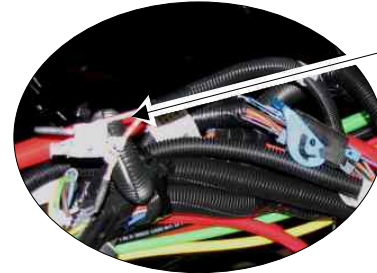

Blunt cut power wires from opt high current power switches located in frame BOC.

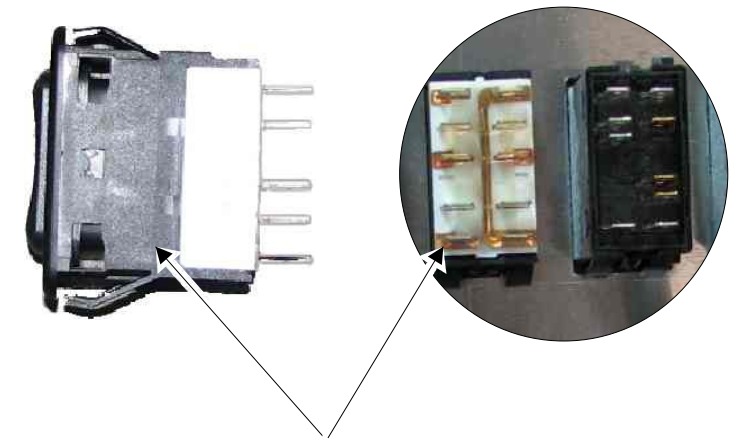

High current switches can be easily identified by the white backing on the switch.

Module 329 Options (Battery Hot):

- 329-007 ILLUMINATED ROCKER SWITCH WITH WIRE TO BACK OF CAB AND MARKER LIGHT CIRCUIT TO JUNCTION BLOCK ON FRAME BACK OF CAB
- 329-010 (2) EXTRA SWITCHES IN DASH WITH INDICATOR LAMP AND WIRE TO CHASSIS AT BACK OF CAB/SLEEPER
- 329-012 (4) EXTRA SWITCHES IN DASH WITH INDICATOR LAMP AND WIRE TO CHASSIS AT BACK OF CAB/SLEEPER
- 329-015 (1) ILLUMINATED ROCKER SWITCH WITH WIRE TO CHASSIS AT BACK OF CAB
- 329-017 (3) EXTRA SWITCHES IN DASH WITH INDICATOR LAMP AND WIRE TO CHASSIS AT BACK OF CAB/SLEEPER
- 329-055 (4) EXTRA SWITCHES IN DASH WITH INDICATOR LAMP AND WIRE TO CHASSIS BACK OF CAB/SLEEPER AND ONE EXTRA SWITCH IN DASH WITH NO WIRING
- 329-077 (8) EXTRA SWITCHES IN DASH; (4) WITH INDICATOR LAMPS AND WIRES TO CHASSIS AT BACK OF CAB, (4) WIRED BY BODY BUILDER
- 329-082 (7) EXTRA SWITCHES IN DASH; (4) WITH INDICATOR LAMPS AND WIRES TO CHASSIS AT BACK OF CAB, (3) WIRED BY BODY BUILDER
- 329-083 (6) EXTRA SWITCHES IN DASH; (4) WITH INDICATOR LAMPS AND WIRES TO CHASSIS AT BACK OF CAB, (2) WIRED BY BODY BUILDER
- 329-1AA ONE ON/OFF/ON ROCKER SWITCH IN THE DASH WITHOUT INDICATOR LIGHT, WIRE ROUTED TO CHASSIS AT BACK OF CAB NO LABEL
- 329-1AB TWO ON/OFF/ON ROCKER SWITCH IN THE DASH WITHOUT INDICATOR LIGHT, WIRE ROUTED TO CHASSIS AT BACK OF CAB NO LABELS

Optional Power Switches:

Additional un-wired dash switches can be ordered for optional switches 5 through 8. These switches will come mounted on the dash to the right of the steering column.

Each switch is equipped with two LED lights; one LED provides switch illumination and on position indication. Constant fused power up to 10A is supplied to each switch from the Power Distribution Module (PDM).

Extra dash switches are not connected and require a customer supplied mating plug and pins to connect the switches to additional wiring. (See plug part numbers on this page)

Connecting a Switch Using a Chassis Junction Block:

Ref service bulletin, Power Switches and Connections # SB-54.39 from your dealer.

Switches will be pre-wired to a Junction block attached to the frame rail near the Chassis Module (CHM). The red wire in the junction block receives power from the output circuit of the optional switch.

IMPORTANT: The power distribution module (PDM) fuse supplying power to the optional switch is rated for 10 amps and this load should not be exceeded by the combined current load of the circuit.

Optional-switch Current Capacity						
No.of Switches	PDM Fuse F25		Switch Output Current Capacity	PDM Fuse F26		Switch Output Current Capacity
	Rating	Switch Protected		Rating	Switch Protected	
1	10A	Switch 1	10A			
2	20A	Shared by switch 1 and 2	10A			
3	20A	Shared by switch 1 and 2	10A	10A	Used by switch 3	10A
4	20A	Shared by switch 1 and 2	10A	20A	Shared by switch 3 and 4	10A

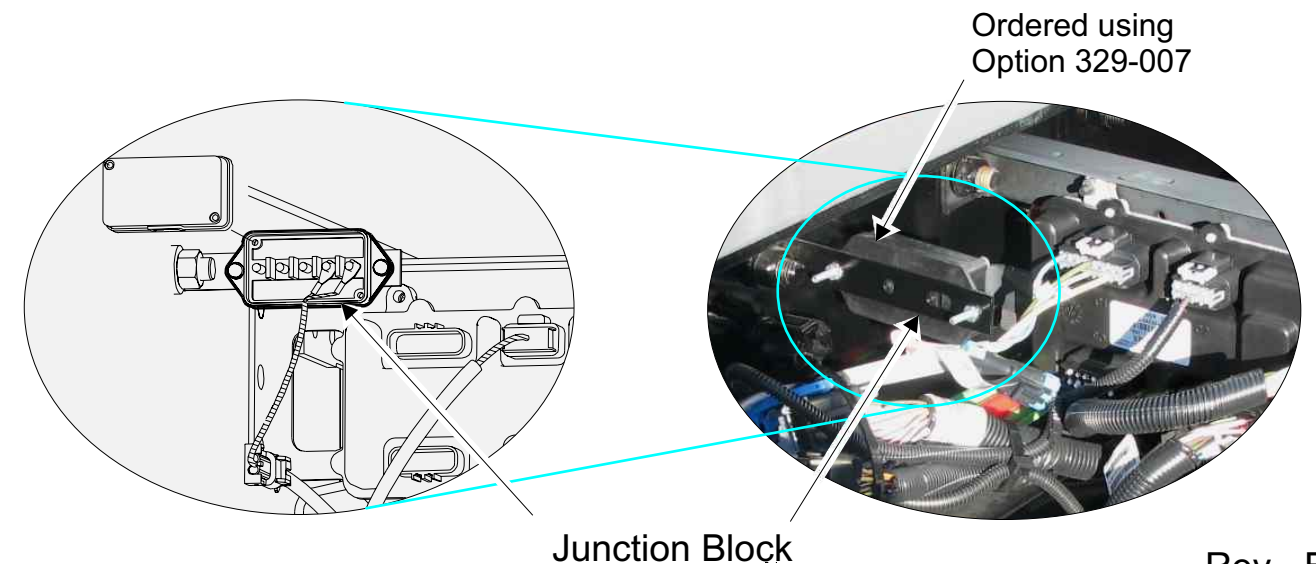

Junction Block

Rev - B

High Current Switch (BH) Schematics

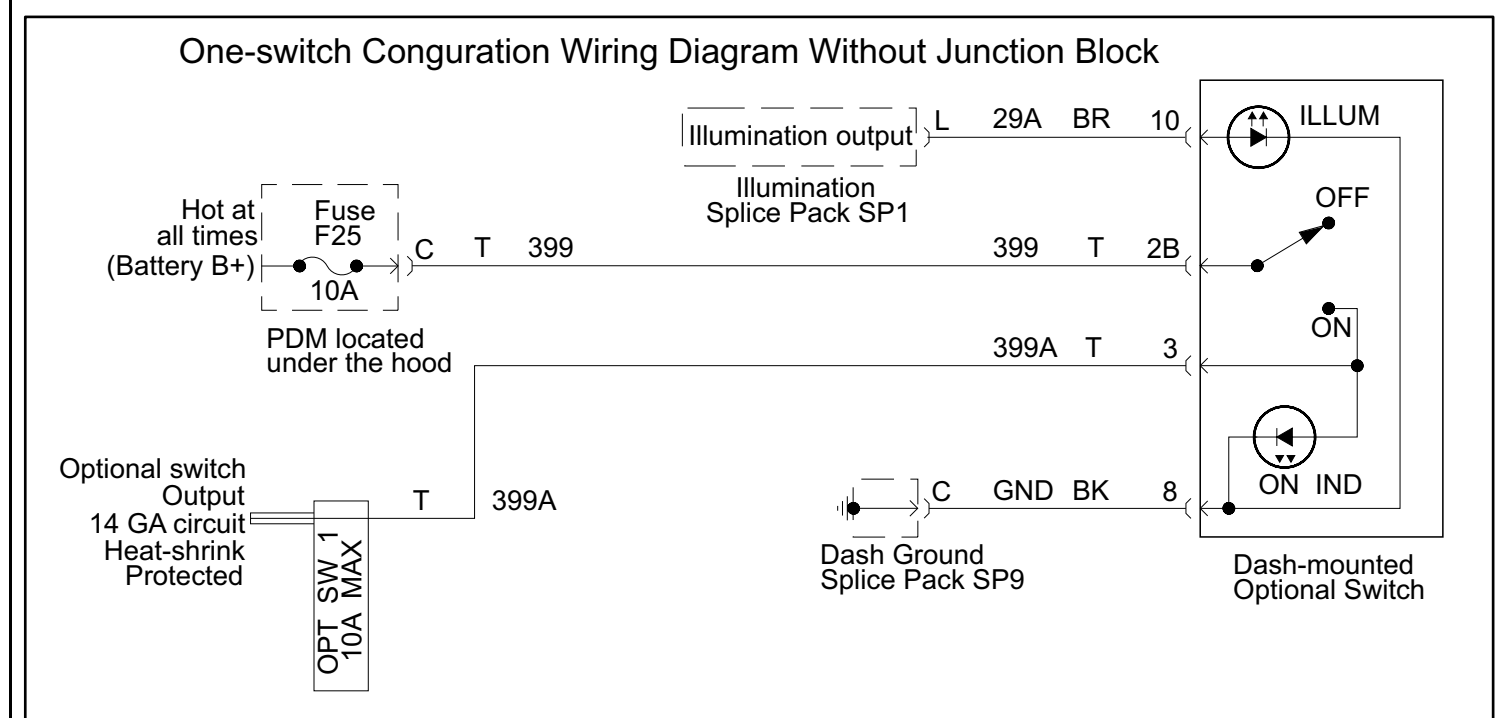
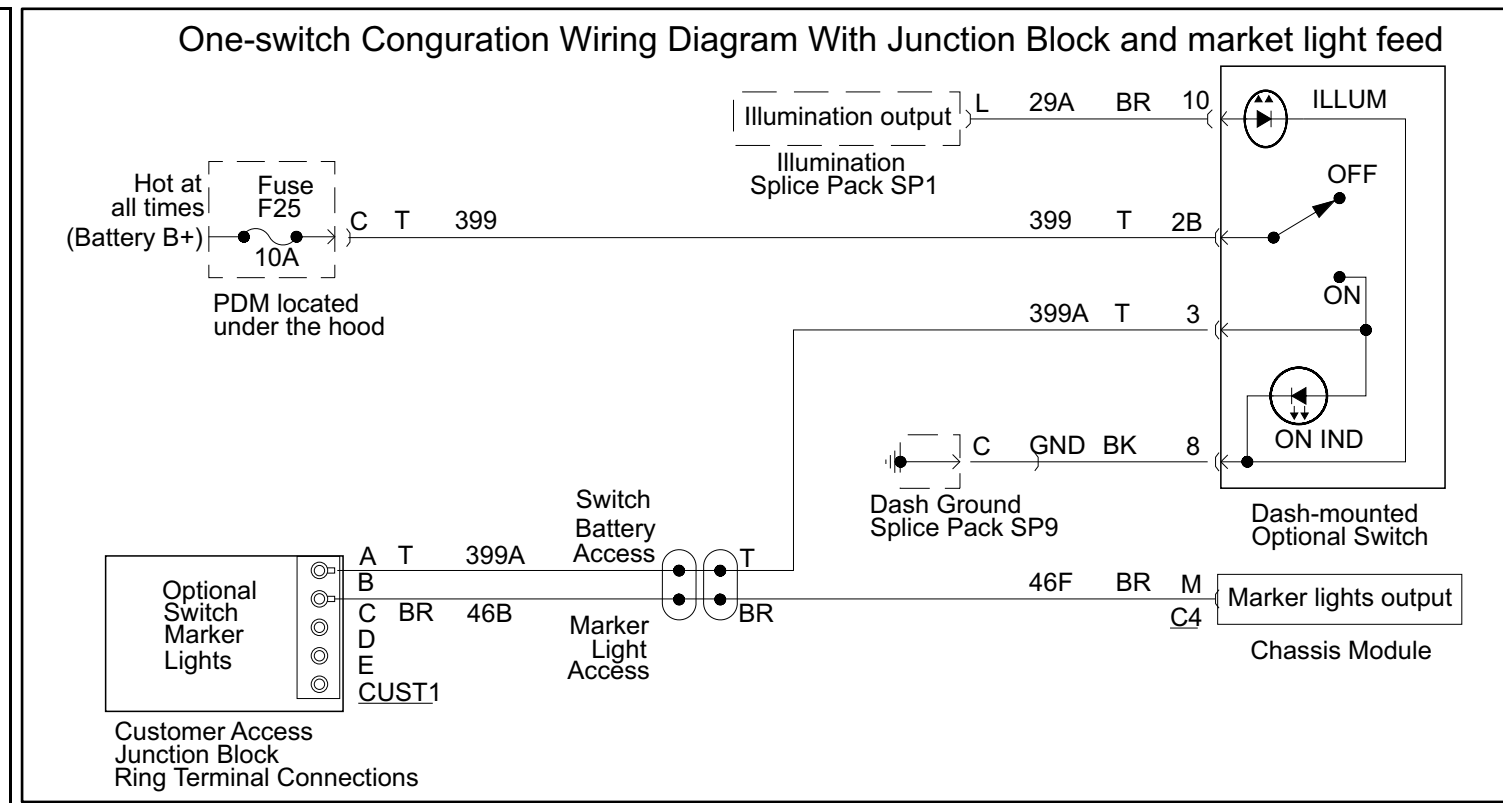
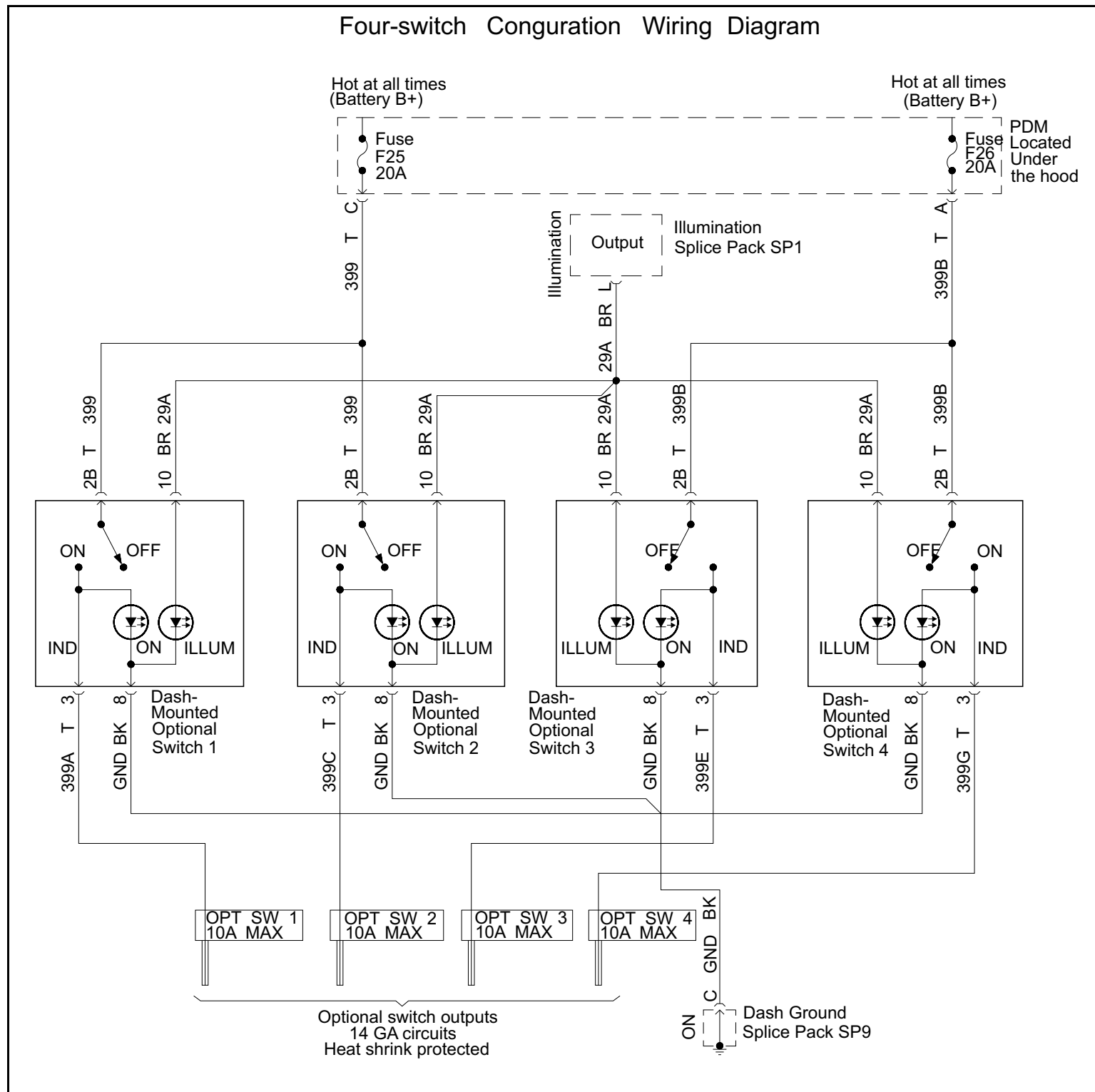

High Current Switches

High current Switch

Optional ignition interlocked or battery powered switches are switch controlled power provisions that are factory installed.

Optional switches can be ordered in a (6)-, (8)-, or (10)-switch configurations.

All optional high current switches mount on the dash, provide fuse protected and ignition interlocked power, and route to a customer access point ending in an in cab junction box.

The junction box will be located under the passenger seat for fix base seat configurations.

The junction box will be shipped loose for customer install for all non-fixed passenger seats.

Optional switches are commonly used to provide battery-powered lighting, as dome, spot, or beacon lights. Other applications include using the optional switch as a triggering mechanism to enable other features, such as hydraulic lift operations or access panel locks.

Module 329 Options (Ignition Interlocked)

- 329-090 (10) IGNITION CONTROLLED EXTRA SWITCHES WITH INDICATOR LIGHTS WIRED TO POWER DISTRIBUTION BOX WITH RELAYS PROVIDING 20 AMPS PER CIRCUIT TO JUNCTION BLOCK AND ONE CIRCUIT AT 30 AMPS
- 329-091 (6) IGNITION CONTROLLED EXTRA SWITCHES WITH INDICATOR LIGHTS WIRED TO POWER DISTRIBUTION BOX WITH RELAYS PROVIDING 20 AMPS PER CIRCUIT TO JUNCTION BLOCK AND ONE CIRCUIT AT 30 AMPS
- 329-092 (8) IGNITION CONTROLLED EXTRA SWITCHES WITH INDICATOR LIGHTS WIRED TO POWER DISTRIBUTION BOX WITH RELAYS PROVIDING 20 AMPS PER CIRCUIT TO JUNCTION BLOCK AND ONE CIRCUIT AT 30 AMPS

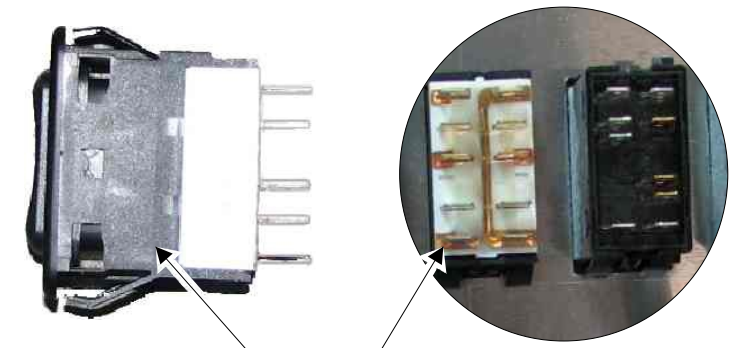

High current switches can be easily identified by the white backing on the switch.

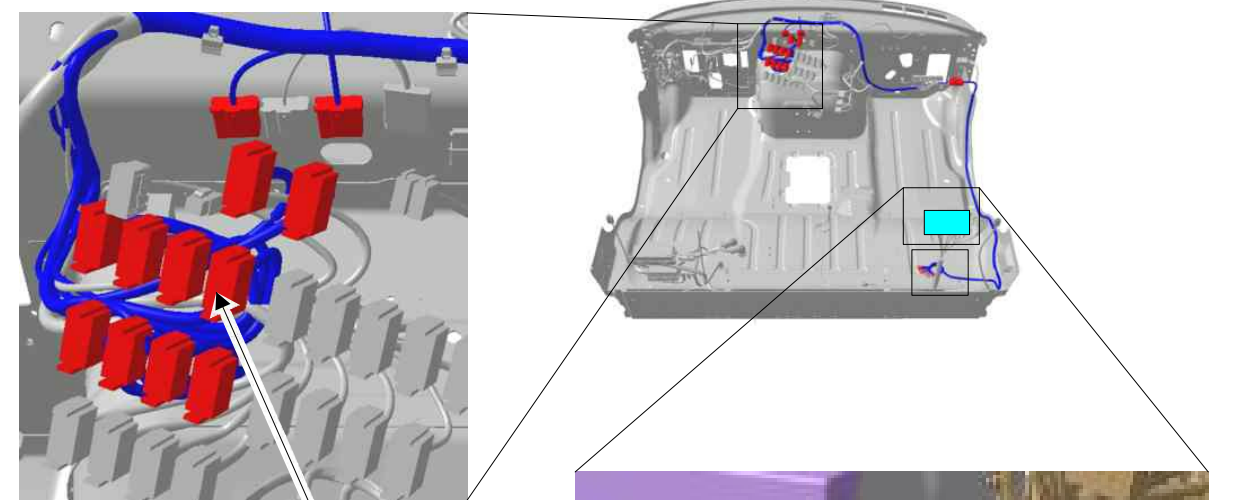

Additional dash switches see page 22 for optional switch labeling

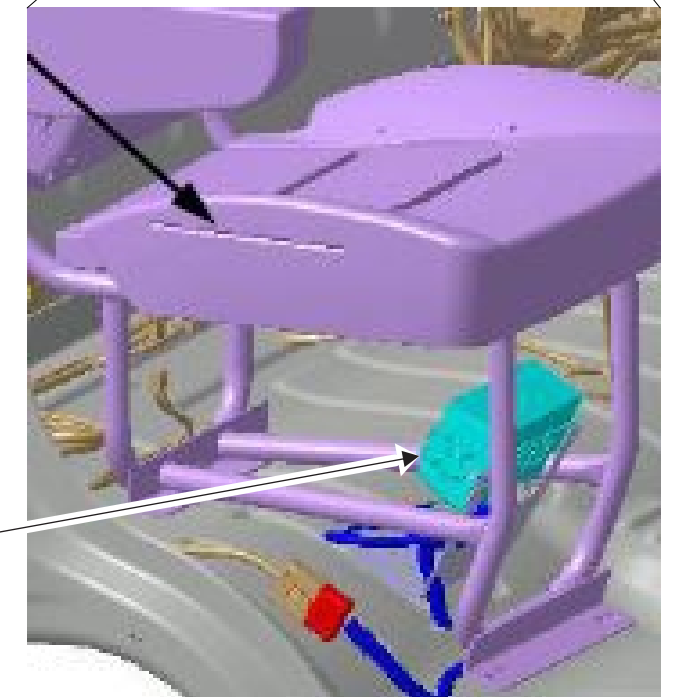

Secondary PNDB Power Net Distribution Box

Note: For Non fixed passenger seat solutions the PNDB will be shipped loose in cab for customer install

Optional-Switch Current Capacity		
No.of Switches	Auxiliary PNDB Power Feed	
	Rating	Switch Protection
6	All 20A	All Switches independently fused
8	All 20A	All Switches independently fused
10	All 20A	All Switches independently fused
Optional SW 1 is fused at 30A in all configurations		

Optional Switch (mod 329)
Fuse and Relay PDM

High Current Schematic (Ignition Interlocked)

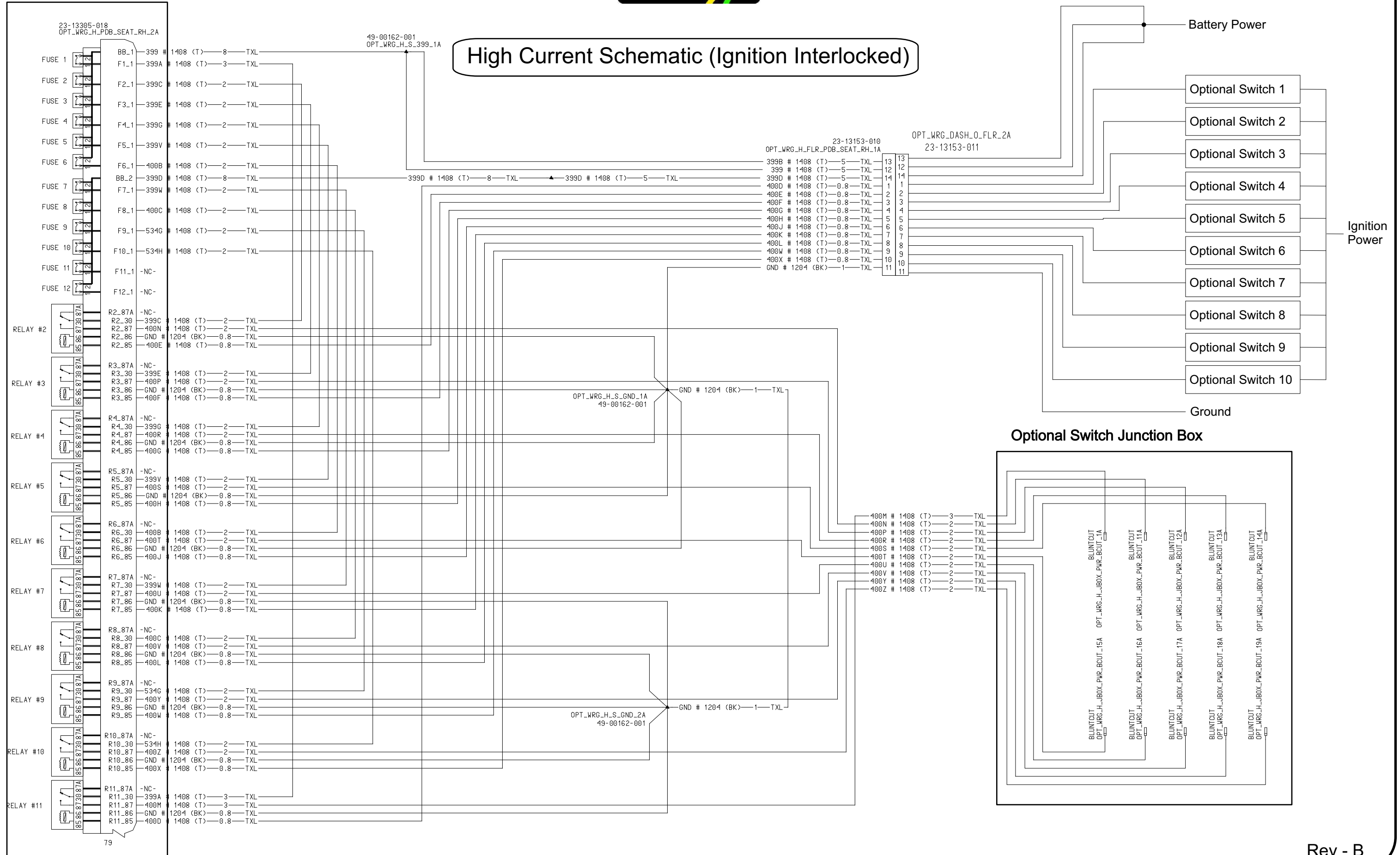

High Current Switch Label Options

Pre labeled High Current Switch Options:

Mod 329 optional switch packages can be customized with the following predefined labels by adding a line note to the sales order.

Step 1
Select the 329-XXX option to drive the number of extra switches you require

Step 2
Have the dealer salesmen add the part numbers for the spare switches from the choices on this page that you would like pre installed.

The addition of the line note will drive a demand and the factory will install the corresponding switch displays in lieu of standard OPT switches in the truck.

Note:
Switches will come pre-wired as per the current optional switch data codes and will not be pre-wired to the locations defined by the switch label.

Option and Blank Switches		
- OPT	A06-30769-076 Option	On (Mom) Off None
- OPT	A06-30769-014 Optional	On Off None
- 	A06-30769-117 Blank	On Off None

Optional Switch Connector				
Connector Pin	Signal Name	Signal Type	Circuit Color	Circuit Number
		FTL Switch Socket PN Socket 06-42557-000		Terminal Pin 23-13213-400 (20-18) Terminal Pin 23-13213-401 (16-14) Terminal Pin 23-13213-402 (12-10)
		Vndr Switch Socket PN Socket PAC15393805		Terminal Pin PAC12015869 (20-18) Terminal Pin PAC12015870 (16-14) Terminal Pin PAC12015830 (12-10)
1				
2B	FusedBatteryPower	Input	T	399 for optional switches 1 and 2. 399B for optional switches 3 and 4.
3	OptionalSwitchOutput	Output	T	399A for optional switch 1. 399C for optional switch 2. 399E for optional switch 3. 399G for optional switch 4.
4				
5B				
6				
7				
8	Ground	Ground	BK	GND
9				
10	IlluminationFeed	Input	BR	29A

Chassis Lamps and Lights		
☀️ PLOW 2 LAMP	A06-30769-158 Plow 2 Lamp	On None Off
- T.GATE LATCH	A06-30769-157 Tail Gate Latch	On None Off
☀️ CAB STRB	A06-30769-155 Cab Strobe	On None Off
☀️ FOG LAMP	A06-30769-092 Fog Lamp	On Off None
☀️ PLOW LAMP	A06-30769-091 Plow Lamp	On Off None
 SALT LIGHT	A06-30769-114 Salt Light	On Off None
 SNDR LAMP	A06-30769-108 Sander Lamp	On Off None
 SPOT LAMP	A06-30769-111 Spot Lamp	On Off None
☀️ SPOT LAMP	A06-30769-023 Spot Lamp	On Off None
☀️ REAR FOG	A06-30769-006 Rear Fog Lamp	On Off None
☀️ UTILITY LAMP	A06-30769-003 Utility Lamp	On Off None
☀️ ROAD LAMP	A06-30769-004 Road Lamp	On Off None

Chassis Switches		
📡 BKUP ALRM	A06-30769-081 Backup Alarm	On (Mom) Off None
- TRLR LATCH	A06-30769-110 Trailer Latch	On Off None
- T.GATE LATCH	A06-30769-109 Tailgate Latch	On Off None
- TRLR AUX	A06-30769-025 Trailer Aux	On Off None
- TRLR AUX	A06-30769-077 Trailer Auxiliary	On (Mom) Off None
Roof Light Switches		
☀️ ALT FLSTR	A06-30769-075 Alternate Flasher	On Off None
☀️ ADV .AMP	A06-30769-024 Advertizing Light	On Off None
☀️ BCN LAMP	A06-30769-029 Beacon Light	On Off None
☀️ DOME	A06-30769-013 Dome Light	On (Mom) Off None
☀️ DOME	A06-30769-034 Dome Light	On Off None
☀️ REAR STRB	A06-30769-113 Rear Strobe	On Off None
☀️ FRONT STRB	A06-30769-112 Front Strobe	On Off None
☀️ SNDR BCN	A06-30769-107 Sander Beacon	On Off None
☀️ FOOT WELL	A06-30769-005 Foot well Light	On Off None

Heater Switches		
☀️ MIRR HEAT	A06-30769-002 Mirror Heat	On Off None
☀️ FUEL HEAT	A06-30769-021 Fuel Heater	On Off None
☀️ BUNK ON BUNK OFF	A06-30769-018 Bunk Heater	On Off None
- EXHST BRK	A06-30769-064 Exhaust Brake	On None Off
Drivetrain Switches		
- CNTR BAL	A06-30769-116 Center Bal	On Off None
- PUMP	A06-30769-115 Pump	On Off None
- AXLE SHIFT	A06-30769-062 Axle Shift	On None Off
- AXLE LIFT	A06-30769-082 Axle Lift	On Off None
OPEN CLOSE	A06-30769-101 Shift Tower	On None Off
- TRANS RTDR	A06-30769-098 Trans Retarder	On Off None
ON PTO OFF	A06-30769-096 PTO	On Off None
- ENG BRK	A06-30769-031 Engine Brake	On Off None
- HDWY CNTL	A06-30769-089 HDWY Control	On Off None
 ENGINE START	A06-30769-149 Engine Start	On (Mom) Off None

Body Builder Lighting Interfaces

Vehicle Interface Lighting

- 353-065 VEHICLE INTERFACE WRG CONN W/ BLUNT CUTS, AT BACK OF CAB
- 353-066 VEHICLE INTERFACE WRG CONN W/ BLUNT CUTS, AT END OF FRAME
- 353-067 VEHICLE INTERFACE WRG CONN W/ PDM AND BLUNT CUTS, AT BACK OF CAB
- 353-068 VEHICLE INTERFACE WRG CONN W/ PDM AND BLUNT CUTS, AT END OF FRAME
- 353-038 MARKER LAMP CONNECTION FOR BODY BUILDERS LOCATED BACK OF CAB

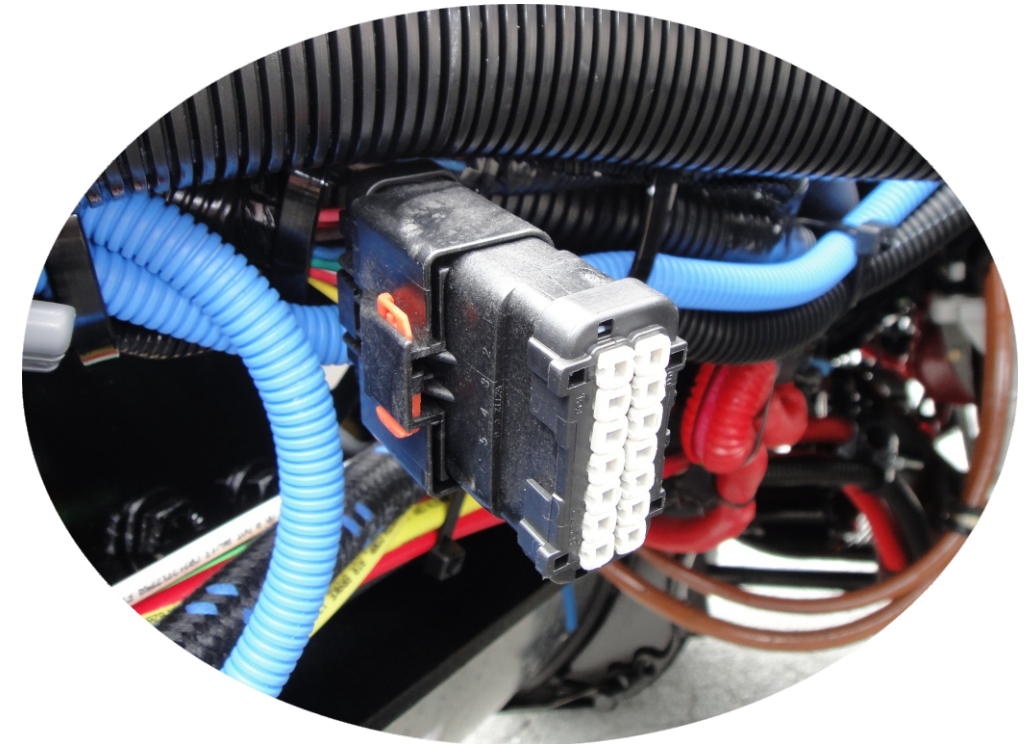

Body Builder Interface Connector
(See page 24 for schematics)

Note: Connector should have an orange ribbon tape within 2" for easy identification

Lighting Interface Harness Mod 353							
		Mating connector supplied with Chassis Apex connector part num FCI54201415 FTL Part # 23-13153-010 TERM-MALE,APEX2.8 FTL Part # 23-13211-010 FCI54001801, -011 FCI54001401 -012 FCI54001001, -013 FCI54001818, -014 FCI54001441					
Connector Pin	Signal Name	Signal Type	Circuit Color	Circuit Number	Marker Lamp Only (353-038)	Low Current (353-022 or 353-023)	High Current (353-026 or 353-027)
1	Tail Lamp	+12V via PDM Fuse 7 With Relay 1 Active	BR	23	-	2 A	20 A
2	Back Up Lamp	+12V via PDM Fuse 12 With Relay 2 Active	DKBL	120B	-	7.5 A	20 A
3	Right Turn Lamp	+12V via PDM Fuse 1 With Relay 3 Active	DKG	38R	-	7.5 A	20 A
4	Right Stop Lamp	+12V via PDM Fuse 6 With Relay 4 Active	R-W	36P	-	6.7 A	20 A
5	Left Stop Lamp	+12V via PDM Fuse 2 With Relay 5 Active	R-W	36N	-	6.7 A	20 A
6	Left Turn Lamp	+12V via PDM Fuse 5 With Relay 6 Active	Y	38L	-	7.5 A	20 A
7	Marker Lamp	+12V via PDM Fuse 3 With Relay 7 Active	BR	46B	20 A	20 A	20 A
8	Ignition Power	+12V via PDM Fuse 4 With Relay 8 Active	PK	52F	-	-	20 A
9	Battery Power	+12V via PDM Fuse 11	R	14U	-	-	20 A
10	Battery Power	+12V via PDM Fuse 8	R	14U	-	-	20 A
11	Ground	Ground	BK	GND	-	-	GND
12	Ground	Ground	BK	GND	-	-	GND
13	Ground	Ground	BK	GND	-	-	GND
14	Ground	Ground	BK	GND	-	-	GND

Trailer and Body Builder Lighting Module

For all 2010 and later configurations specified with the trailer and body builder options, Freightliner provides an in-cab lighting module that provides high current capacity circuits that are protected from the elements and east to access for maintenance and assembly people/

Body Builder PDM

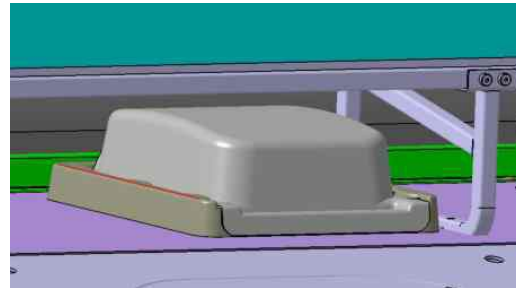

Floor Mount Configuration for Extend Cab Units

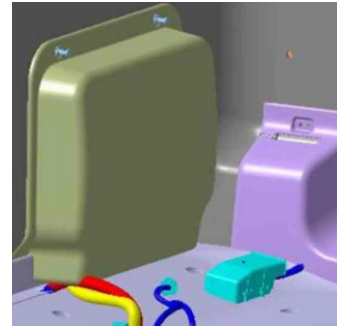

Back wall Configuration for Day Cab Units

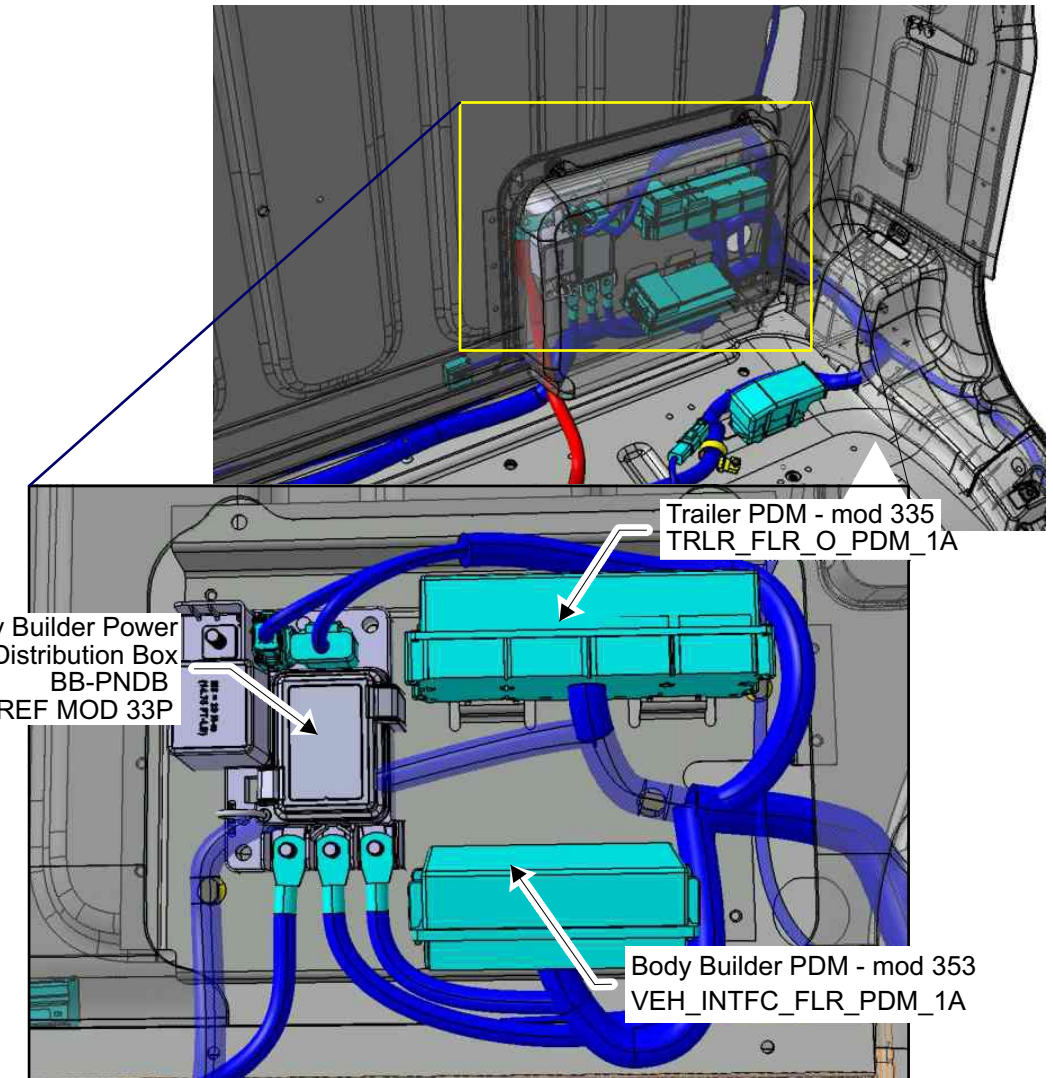

Trailer PDM - mod 335
TRLR_FLR_O_PDM_1A

Body Builder Power Net Distribution Box
BB-PNDB
REF MOD 33P

Body Builder PDM - mod 353
VEH_INTFC_FLR_PDM_1A

Body Builder PDM VEH_INTFC_FLR_PDM_1A

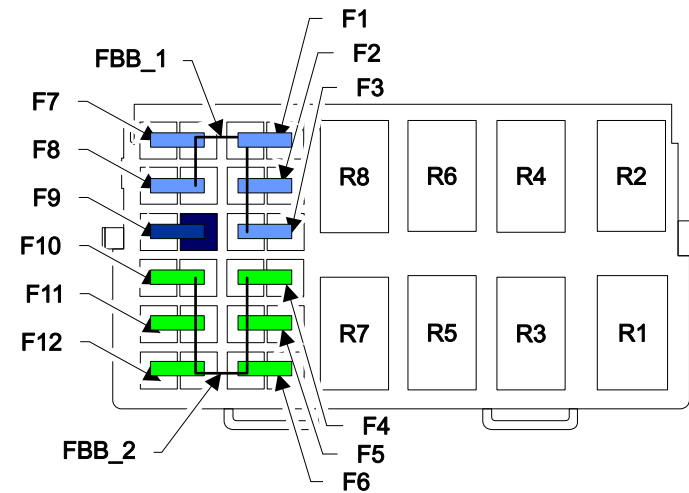

Fuse Location	Fuse Rating	Function	Relay Location	Relay Rating	Function
F1	20A	Right Turn Lamp	R1	Micro	Tail Lamp
F2	20A	Left Stop Lamp	R2	Micro	Backup Lamp
F3	20A	Marker Lamp	R3	Micro	Right Turn Lamp
F4	20A	Ignition Power	R4	Micro	Right Stop Lamp
F5	20A	Left Turn Lamp	R5	Micro	Left Stop Lamp
F6	20A	Right Stop Lamp	R6	Micro	Left Turn Lamp
F7	20A	Tail Lamp	R7	Micro	Marker Lamp
F8	20A	Battery Power	R8	Micro	Ignition Power
F9	---	Blocked			
F10	---	Spare			
F11	20A	Battery Power			
F12	20A	Backup Lamp			

Cab Floor Connector Pinout

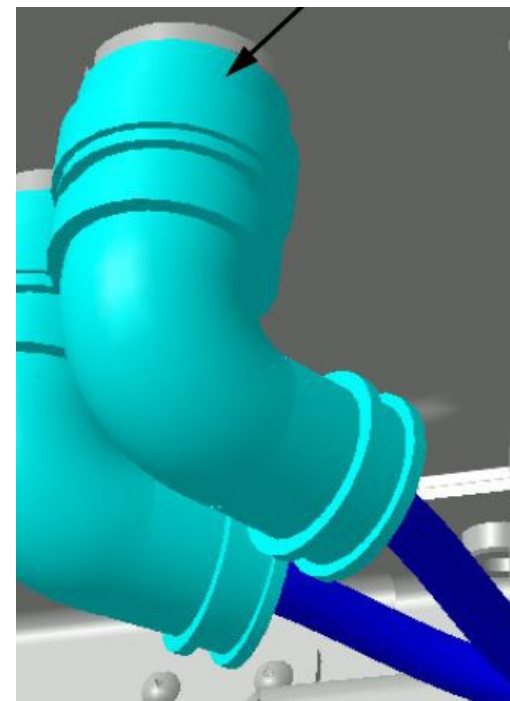

UCAB_H_FLR_2A Under-Cab Harness connecting to Cab Floor Harness			
Pin	Wire size	Usage Description	Circuit #
A	16-18	Marker Lamp Relay R4_87	46A
B	16-18	Left Turn Relay R6_87	38L
C	16-18	Stop Lamp Relay R5_87	36B
D	16-18	Right Turn Relay R7_87	38R
E	16-18	Tail Lamp Relay R3_87	23
F	16-18	Trailer Power R2_87	45
G	16-18	20 amp battery Fuses	14U
H	16-18	20 amp battery Fuses	14U
J	16-18	Left Tail Lamp	23
K	16-18	Backup Lamp	120B
L	16-18	Right Turn Lamp	38R
M	16-18	Right Stop Lamp	36P
N	16-18	Left Stop Lamp	36N
P	16-18	Left Turn Lamp	38L
R	16-18	Marker Lamp	46B
S	16-18	Ignition Power	52F

High Current Interface

Body Builder PDM

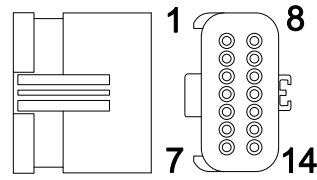

Mating connector supplied with Chassis
Apex Connector part Num FCI54201415
FTL Part # 23-13153-010
FTL Terminal Part # 23-13211-010, -011, -012

Interface Connector

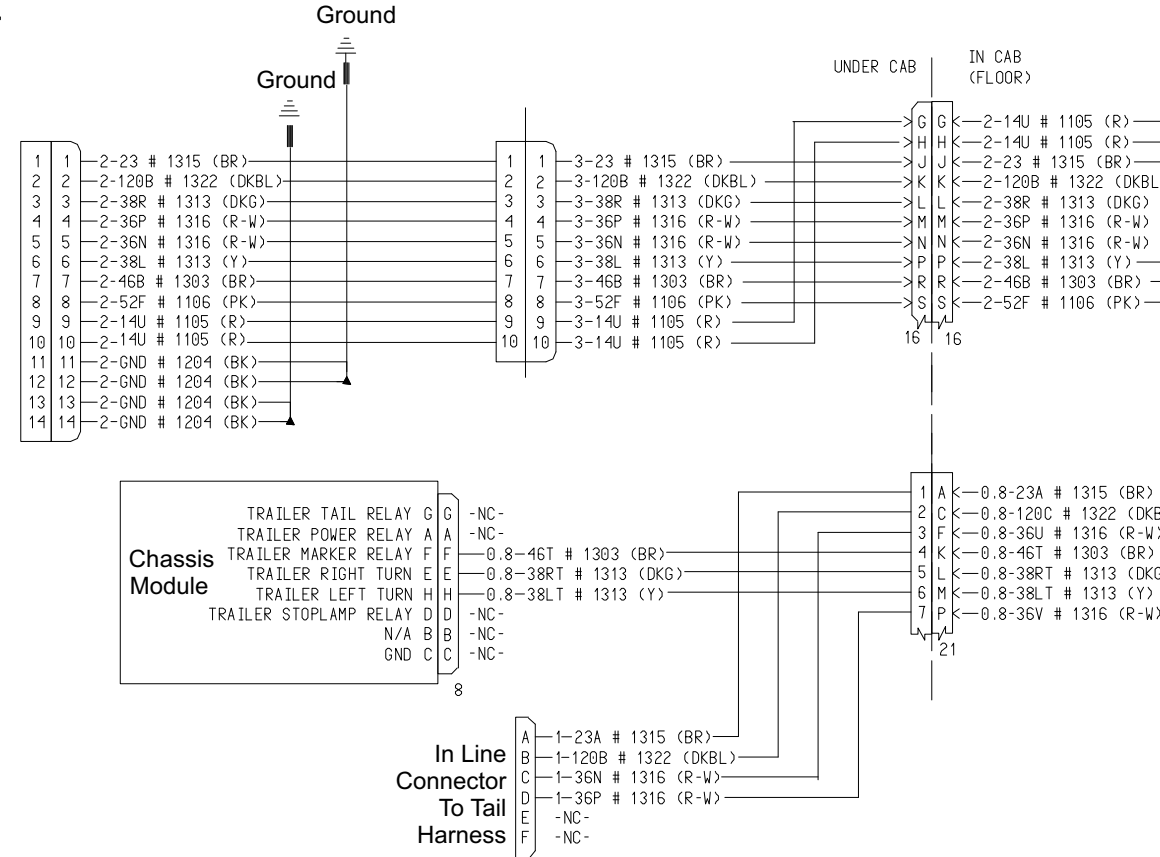

353-026 and 353-027 Schematic

Low Current Interface

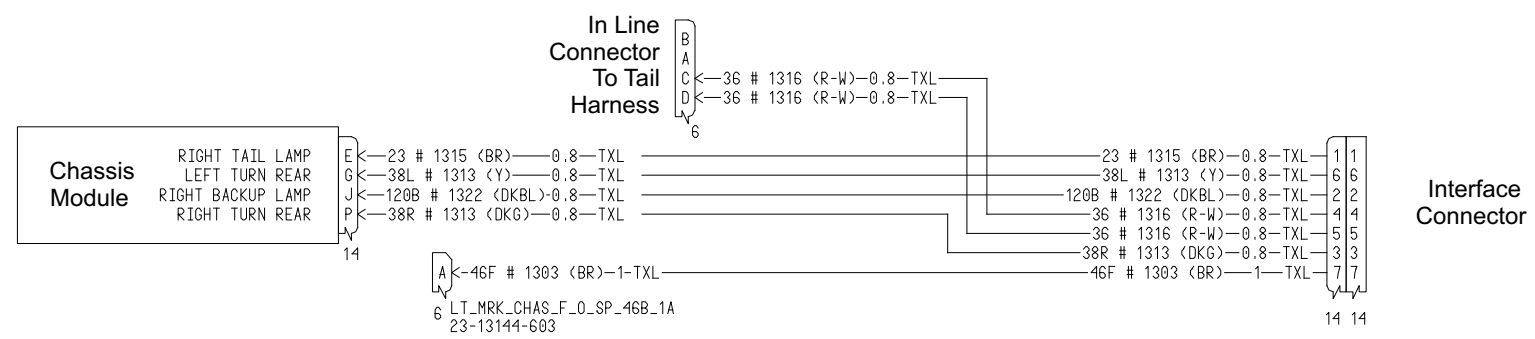

353-022 and 353-023 Schematic

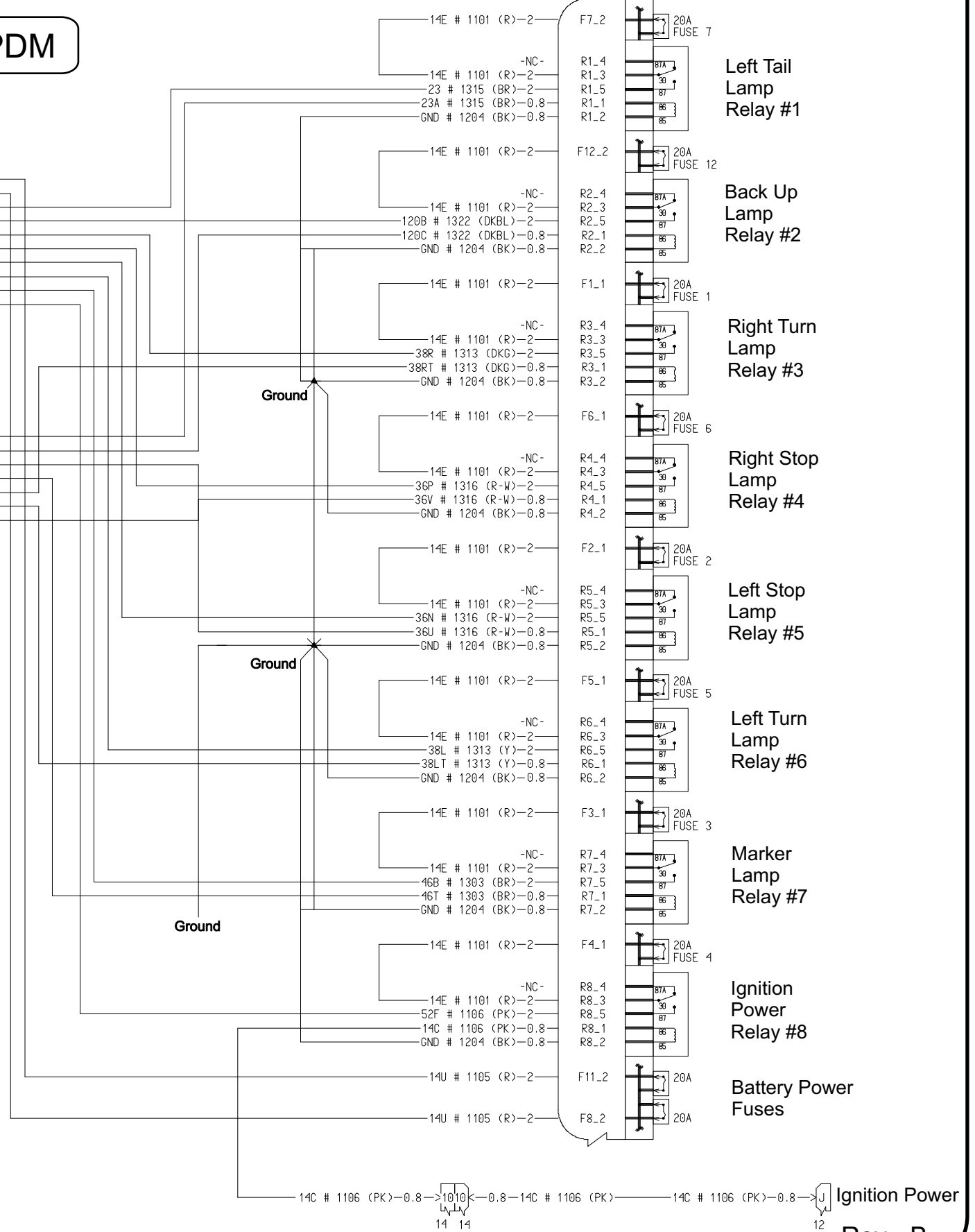

Trailer and Body Builder Lighting Module

For all 2010 and later configurations specified with the trailer and body builder options, Freightliner provides an in-cab trailer control module that provides high current capacity circuits that are protected from the elements and easy to access for maintenance and assembly people.

Reference modules: 287, 87M, 296, 308

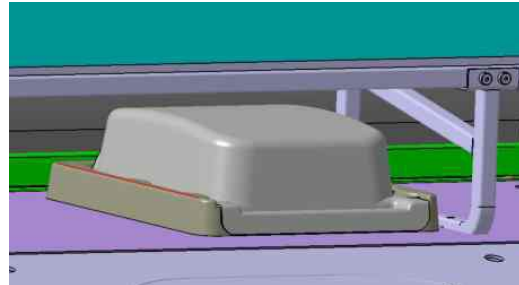

Floor Mount Configuration for Extend Cab Units

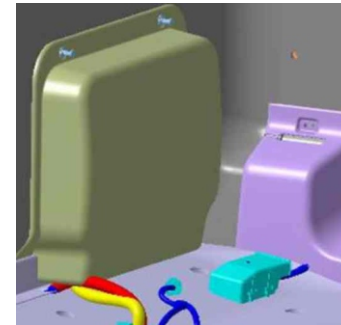

Back wall Configuration for Day Cab Units

Trailer PDM

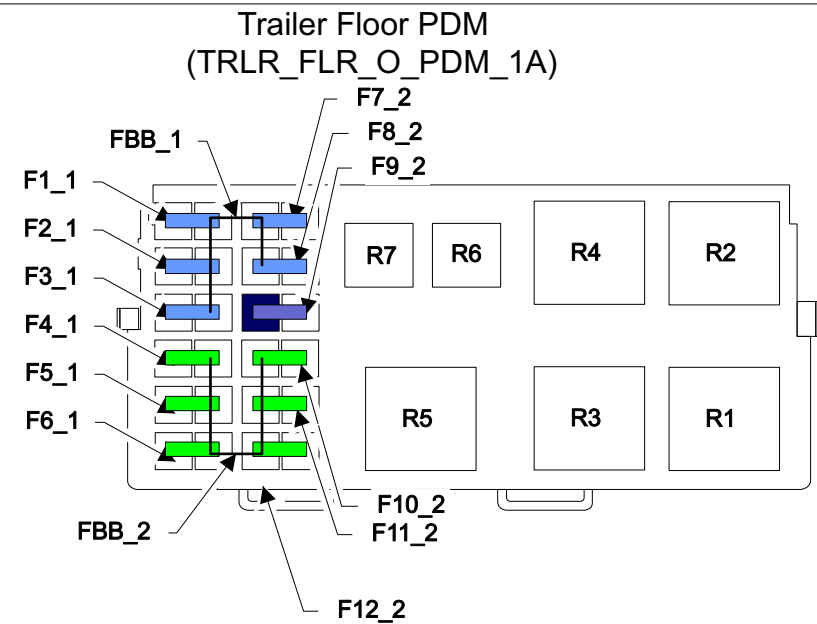
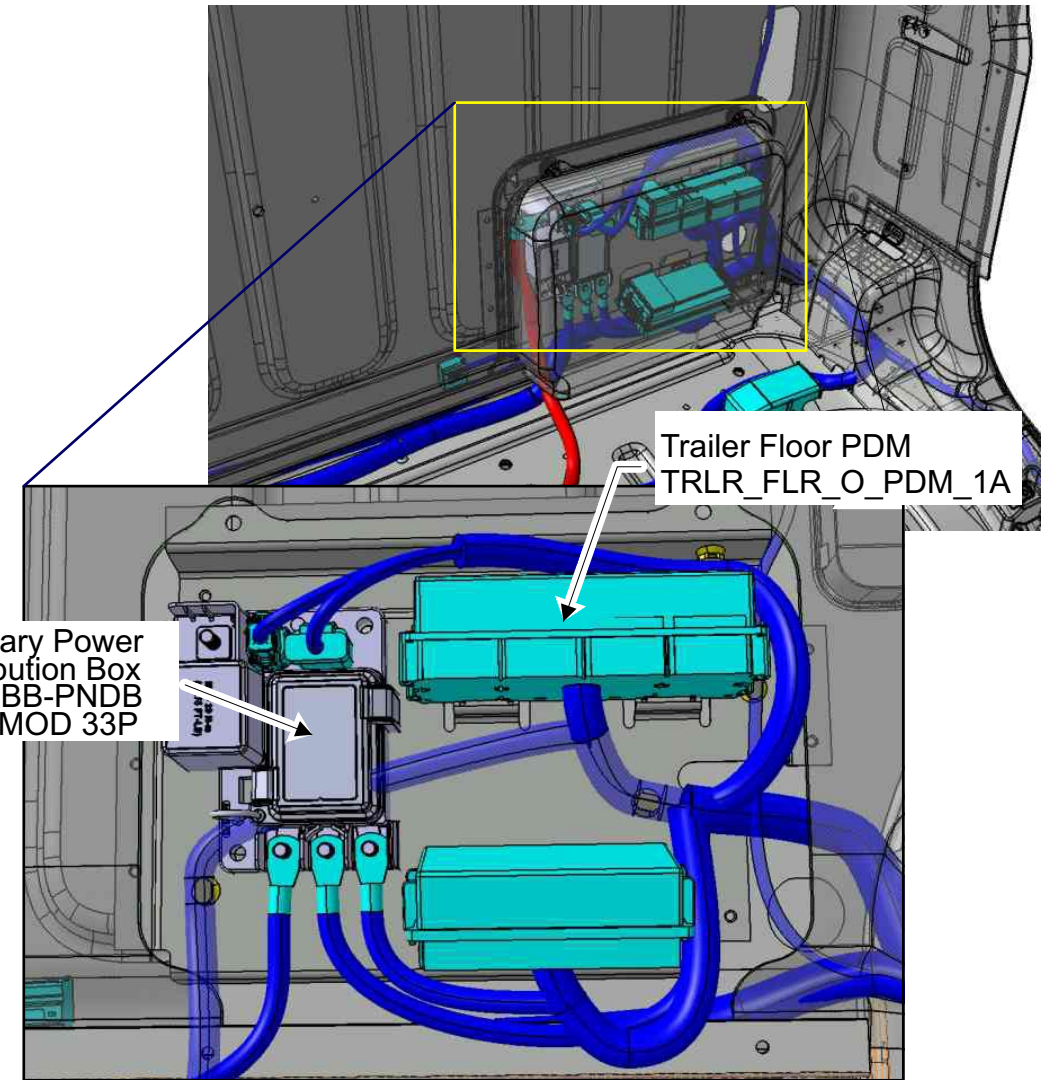

Fuse Location	Fuse Rating	Function	Relay Location	Relay Rating	Function
F1	30A	Supplemental Trailer	R1	Mini	Supplemental Trailer
F2	20A	Tail Lamp	R2	Mini	Trailer Power
F3	20A	Stop Lamp	R3	Mini	Tail Lamp
F4	20A	Right Turn Lamp	R4	Mini	Marker Lamp
F5	20A	Left Turn Lamp	R5	Mini	Stop Lamp
F6	20A	Marker Lamp	R6	Micro	Left Turn Lamp
F7	---	Spare	R7	Micro	Right Turn Lamp
F8	---	Spare			
F9	---	Blocked			
F10	---	Spare			
F11	---	Spare			
F12	30A	Trailer Power			

Cab Floor Connector Pinout

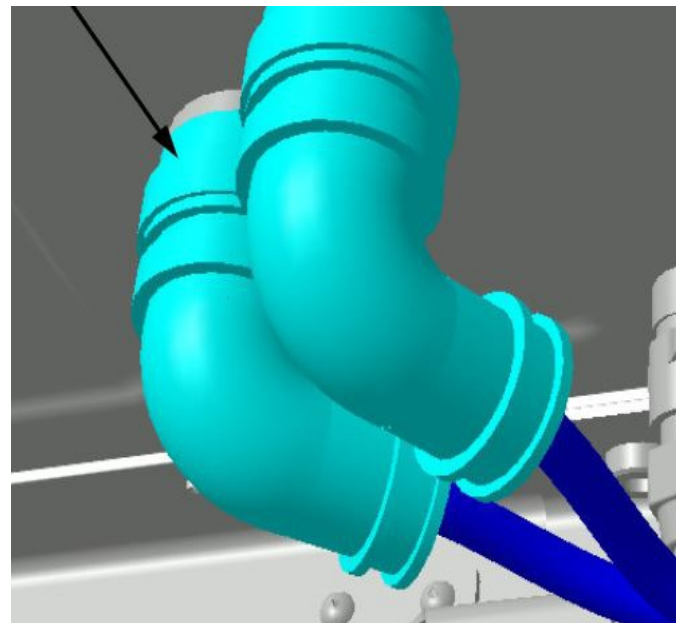

UCAB_H_FLR_3A Under-Cab Harness connecting to Cab Floor Harness			
Pin	Wire size	Usage Description	Circuit #
A	16-18	Left Tail Lamp R1_1	23A
B	12-14	---	
C	16-18	Back up Lamp R2_1	120C
D	12-14	PLC Filter Mod 296	376E
E	12-14	PLC Filter Mod 296	376F2
F	16-18	Left Stop Lamp R5_1	36U
G	12-14	---	
H	16-18	Tail Lamp Relay R3_86	23A
J	16-18	Trailer Power Relay R2_85	52C
K	16-18	Trailer Marker Relay R7_1	46T
L	16-18	Trailer Right Turn R3_1	38RT
M	16-18	Trailer Left Turn R6_1	38LT
N	16-18	Stop Lamp R5_86	36
P	16-18	Right Stop Lamp R4_1	36V
R	16-18	Aux PNDB Disconnect Off Signal	425J
S	16-18	Aux PNDB Disconnect LED Indicator	425H
T	16-18	Aux PNDB Disconnect Return Signal	425K
U	16-18	---	
V	16-18	---	
W	16-18	---	
X	16-18	---	

Mod 296/297 Combination Stop/Turn

- 296-025 PRIMARY CONNECTOR/RECEPTACLE WIRED FOR COMBINATION STOP/TURN, CENTER PIN POWERED THROUGH IGNITION
- 296-027 PRIMARY CONNECTOR/RECEPTACLE WIRED FOR COMBO STOP/TURN, CENTER PIN POWERED THROUGH IGNITION WITH STOP SIGNAL PRE-WIRE PACKAGE
- 297-001 SAE J560 7-WAY PRIMARY TRAILER CABLE RECEPTACLE MOUNTED END OF FRAME
- 297-005 SAE J560 7-WAY PRIMARY TRAILER CABLE RECEPTACLE MOUNTED ON CHASSIS BACK OF CAB/SLEEPER
- 297-008 SAE J560 7-WAY PRIMARY TRAILER CABLE RECEPTACLE BRACKET MOUNTED LH DECK BACK OF CAB

Trailer Electrical System (Combination)

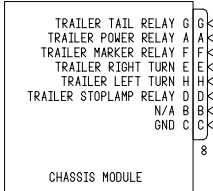
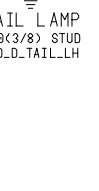
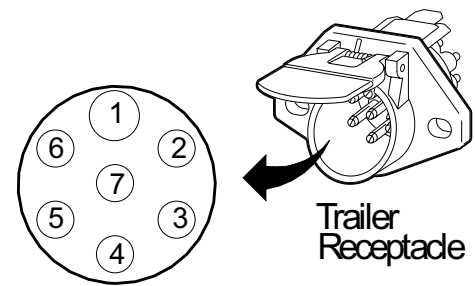
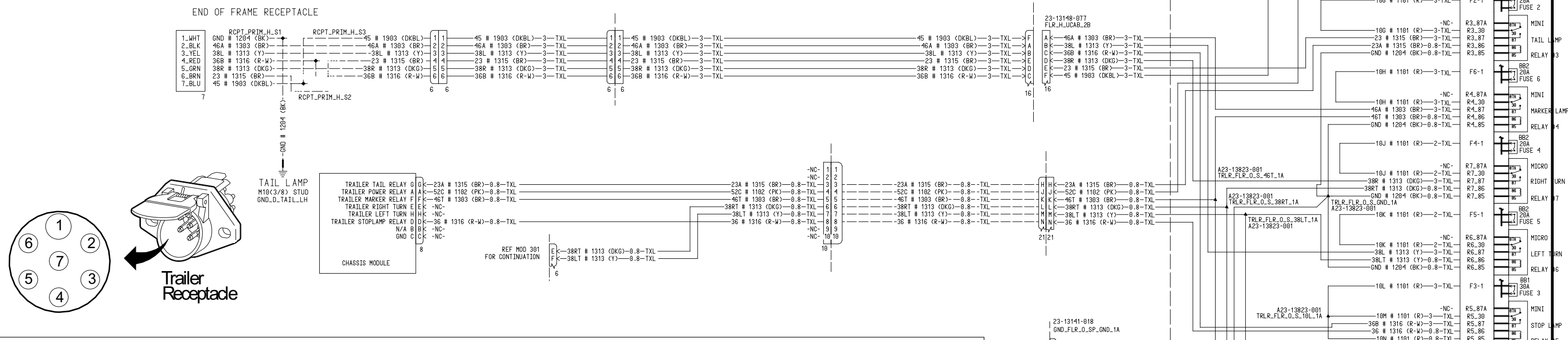

REF MOD 301 FOR CONTINUATION

SEE MODULE 289

ELECTRIC TRAILER BRAKE PRE-WIRE INCLUDED WITH 296-027

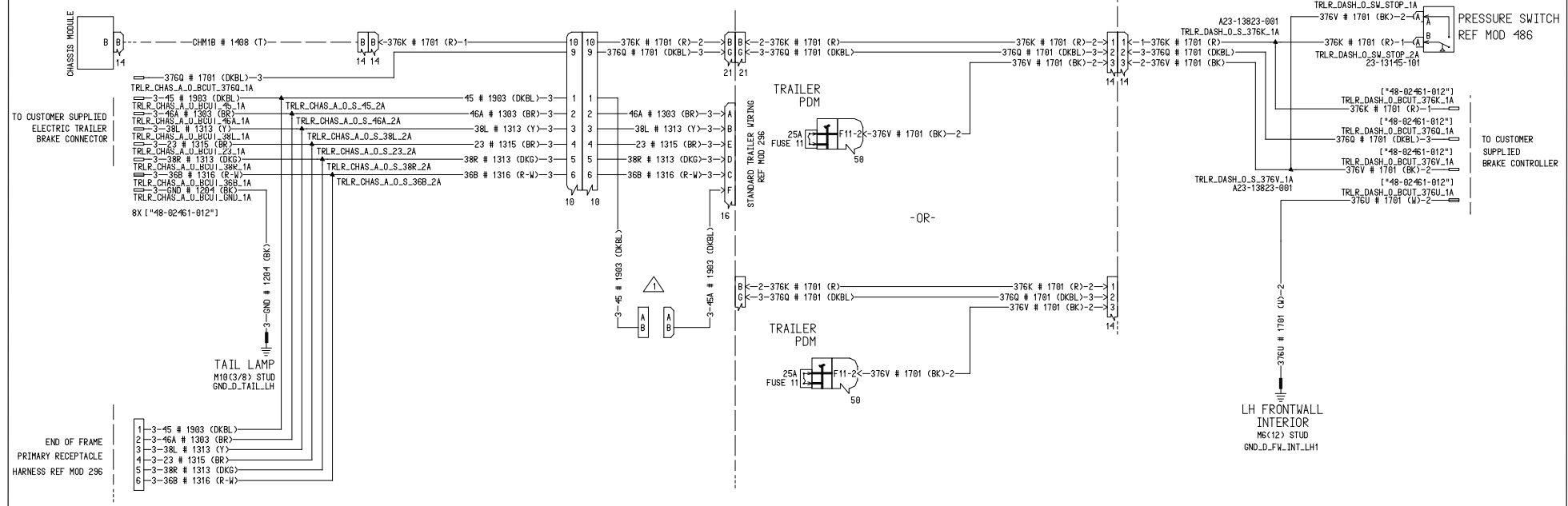

ELECTRIC TRAILER PRE-WIRE BLUNT CUTS UNDER STEERING COLUMN AND END OF FRAME

Body Builder Floor Plug Interface

Connections to the trailer and body builder unit are achieved using a 76 Pin plug located on the cab floor rear of the driver seat.

Refer to the diagram and chart on this page to determine what pins are used for connections and what pins are available for additional body builder connections.

Trailer and Bodybuilder Floor Connections

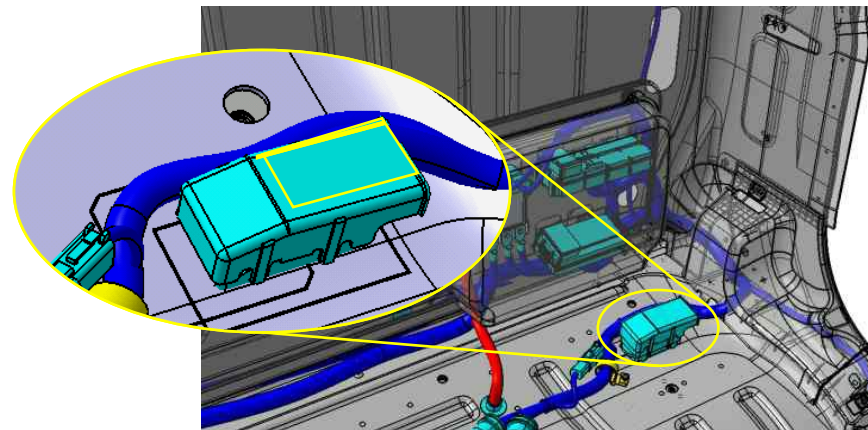
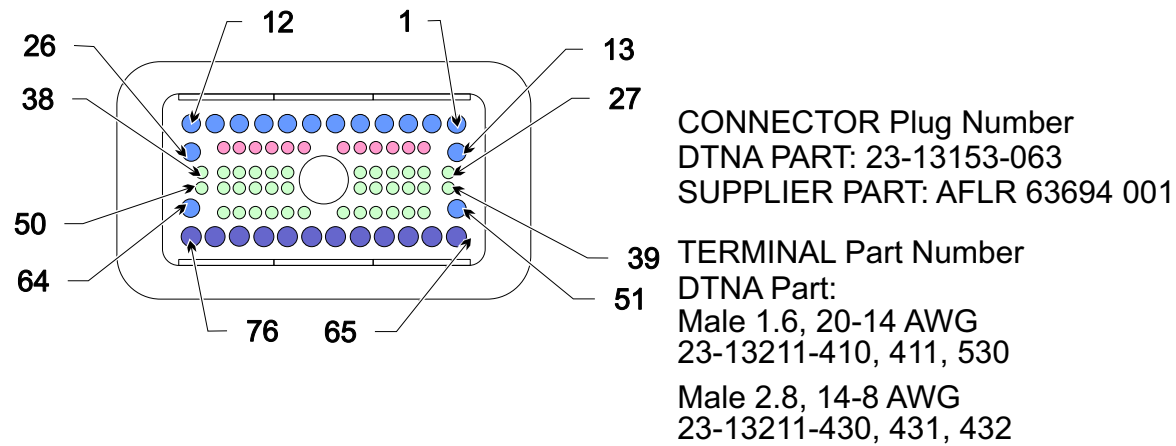

UCAB_H_FLR_1A							
Pin	Wire size	Usage Description	Circuit #	Pin	Pin size mm	Usage Description	Load Limit
1	12-14	--		39	16-18	--	
2	12-14	--		40	16-18	--	
3	12-14	--		41	16-18	--	
4	12-14	--		42	16-18	--	
5	12-14	--		43	16-18	--	
6	12-14	--		44	16-18	--	
7	12-14	--		45	16-18	--	
8	12-14	--		46	16-18	--	
9	12-14	--		47	16-18	Engine Control Dash	483Z
10	12-14	--		48	16-18	Remote VSG Select	439U
11	12-14	--		49	16-18	Cruise Control On/Off Enable	492U
12	12-14	--		50	16-18	Cruise Control Set/Coast	483A
13	12-14	--		51	12-14	--	
14	16-18	--		52	16-18	Cruise Control Resume/Control	483B
15	16-18	Starter, Engine	15	53	16-18	Limiter 8	439V1
16	16-18	Ground	GND	54	16-18	Limiter 1	439V2
17	16-18	--		55	16-18	Tachometer	483E
18	16-18	--		56	16-18	Throttle Inhibit	492Z
19	16-18	--		57	16-18	Remote Accelerator Select	483N
20	16-18	--		58	16-18	Variable Speed Governor	483C
21	16-18	--		59	16-18	+5V Sensor Supply	483D
22	16-18	Disconnect Off Signal	425H	60	16-18	Engine Control Dash	492Y
23	16-18	Disconnect LED Indicator	425K	61	16-18	Dash Power and Ignition	439A
24	16-18	Disconnect Return Signal	425J	62	16-18	CAV 15 -NC- (Reserved)	CAV15
25	16-18	Disconnect GND	GNDE	63	16-18	CAV 16 -NC- (Reserved)	CAV16
26	12-14	--		64	12-14	--	
27	16-18	--		65	12-14	--	
28	16-18	--		66	12-14	--	
29	16-18	--		67	12-14	--	
30	16-18	--		68	12-14	--	
31	16-18	--		69	12-14	--	
32	16-18	--		70	12-14	--	
33	16-18	--		71	12-14	--	
34	16-18	--		72	12-14	--	
35	16-18	--		73	12-14	--	
36	16-18	--		74	12-14	--	
37	16-18	--		75	12-14	--	
38	16-18	--		76	12-14	--	

Tail Lights and EOF Connections

Body builders utilizing factory lights and needing additional lighting interfacing should use the 353 data codes for body builder interfaces.

Body builders wishing to supply their own taillights can order the “Wiring Only” option shown below.

Many connectors come with mating connectors included and require only the terminals to be supplied by the body builder.

Tail Lights

Data Code	Description	LED	Incan-descent	Wiring Only	Additional Harness Length (ft)	Combo Stop/Turn	Separate Stop/Turn	Grommet Mounted	Flange Mounted	Lamp Configuration	Truck Configurations
294-001	INTEGRAL STOP/TAIL/BACKUP LIGHTS	-	X	-	-	X	-	-	-		<p><u>Straight Truck Configurations</u></p>
294-002	TRUCK-LITE 40 STOP/TAIL WITH SEPARATE BACKUP LIGHTS GROMMET MOUNTED	-	X	-	-	X	-	X	-		
294-017	INTEGRAL STOP/TAIL/BACKUP LIGHTS WITH 7 FEET ADDITIONAL WIRE AT CHASSIS END OF FRAME	-	X	-	7	X	-	-	-		
294-021	TRUCK-LITE 3 CHAMBER MODULES WITH 45 SERIES SEALED BEAM LAMPS	-	X	-	-	-	X	-	-		
294-027	WIRING ONLY WITH SEPARATE STOP AND TURN LIGHT CIRCUITS TO END OF FRAME FOR CUSTOMER FURNISHED LAMPS	-	-	X	-	-	X	-	-		
294-037	INTEGRAL STOP/TAIL/BACKUP LIGHTS WITH 36 INCHES ADDITIONAL WIRE AT CHASSIS END OF FRAME	-	X	-	3	X	-	-	-		
294-042	FREIGHTLINER LED FLANGE MOUNTED STOP/TAIL/TURN LIGHTS WITH SEPARATE INCANDESCENT BACKUP LIGHTS	X	-	-	-	X	-	-	X		
294-046	OMIT STOP/TAIL/BACKUP LIGHTS AND PROVIDE WIRING WITH SEPARATE STOP/TURN WIRES TO 4 FEET BEYOND END OF FRAME	-	-	X	4	-	X	-	-		
294-050	FREIGHTLINER LED STOP/TAIL/TURN/BACKUP/LICENSE LIGHTS BY TRUCK-LITE	X	-	-	-	X	-	-	X		
294-081	GROTE#53302 10-DIODE LED STOP/TAIL/TURN LIGHTS MOUNTED ON REAR CROSSMEMBER	X	-	-	-	X	-	-	X		
294-090	OMIT STOP/TAIL/BACKUP LIGHTS AND PROVIDE WIRING FOR COMBINED STOP/TURN LIGHTS TO FOUR FEET BEYOND END OF FRAME	-	-	X	4	X	-	-	-		
294-091	FREIGHTLINER LED FLANGE MOUNTED STOP/TAIL/TURN LIGHTS WITH SEPARATE BACKUP LIGHTS AND ADDITIONAL 7 FEET WIRING END OF FRAME	X	-	-	7	X	-	-	X		
294-094	OMIT STOP/TAIL/BACKUP LIGHTS AND PROVIDE WIRING WITH SEPARATE STOP/TAIL WIRES TO 7 FEET BEYOND END OF FRAME	-	-	X	7	-	X	-	-		
294-095	WIRING HARNESS ONLY TO END OF FRAME FOR STOP/TAIL/TURN WITH BRAKE LIGHT ACTIVATION WITH PARK BRAKE APPLIED WITH IGNITION	-	-	X	-	X	-	-	-		

Tractor Configurations



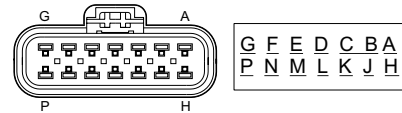

Pinouts at CHM Connector C1

Connector Pin	Signal Name	Signal Type	Circuit Color	Circuit Number	Current Capacity
C1-A	LeftBackupLight(combinationstop/turnsignal)	DigitalOutput	DKBL	120B	7.45A*
C1-A	LeftBackupLight(separatestop/turnsignal)	DigitalOutput	DKBL	120B	7.45A*
C1-B			T	OPTA	
C1-C			T	OPTB	
C1-D	LeftTaillightPass-through	Pass-through	BR	23	1.0A†
C1-E	RightTaillightPass-through	Pass-through	BR	23A	1.0A†
C1-F	LicensePlateLight	DigitalOutput	BR	23C	1.0A†
C1-G	LeftRearTurnSignalLight(separatestop/turnsignal)	DigitalOutput	Y	38L	7.45A*
C1-H	BackupAlarm	DigitalOutput	DKBL	120B	7.45A*
C1-J	RightBackupLight	DigitalOutput	DKBL	120B	7.45A*
C1-K			T	OPTC	
C1-L	RightStopLight(combinationstop/turnsignal)	DigitalOutput	R-W	39R	7.45A
C1-L	RightStopLight(separatestop/turnsignal)	DigitalOutput	R-W	39R	7.45A
C1-M			T	OPTD	
C1-N	LeftStop/TurnSignalLight(combinationstop/turnsignal)	DigitalOutput	Y	39L	7.45A
C1-N	LeftStopLight(separatestop/turnsignal)	DigitalOutput	R-W	39L	7.45A
C1-P	RightRearTurnSignalLight(separatestop/turnsignal)	DigitalOutput	DKG	38R	7.45A§

* Pins C1-A, C1-H, and C1-J are fed from the same CHM circuit board trace. The max combined current cap for all three pins is 7.45A.
 † Pins C1-D, C1-E, and C1-F are fed from the same CHM circuit board trace. The max combined current cap for all three pins is 1A.
 ‡ Pins C1-G, C2-H, and C3-N are fed by the same CHM circuit board trace. The max combined current cap for all three pins is 7.45A.
 § Pins C1-P, C2-E, and C3-R are fed by the same CHM circuit board trace. The max combined current cap for all three pins is 7.45A.

Lighting Outputs For Integrated RearLights (Combination stop/turn signal)

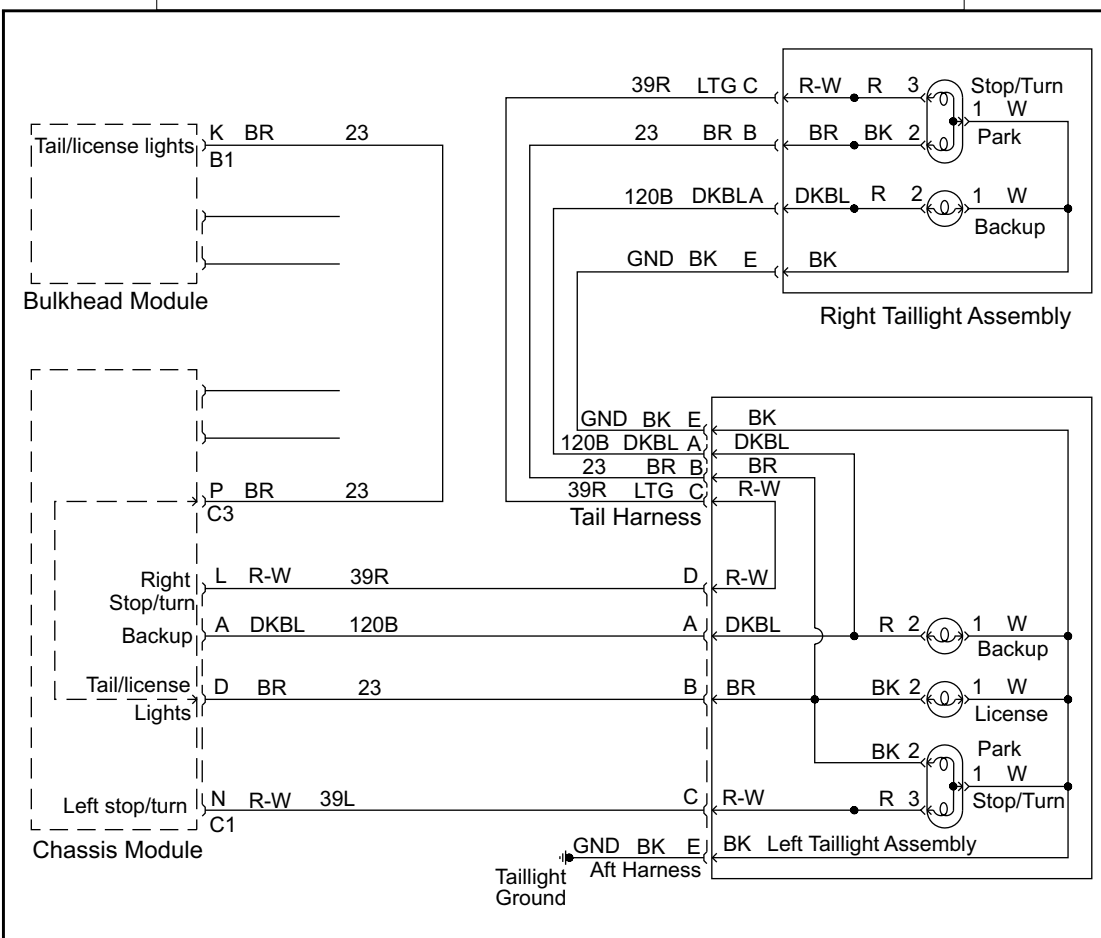

Tail Lights Schematics

Modules: 301, 311, 35H, 877, 30J

RearLighting Connection (separate stop/turn signal)

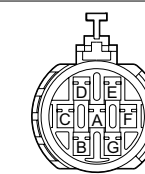
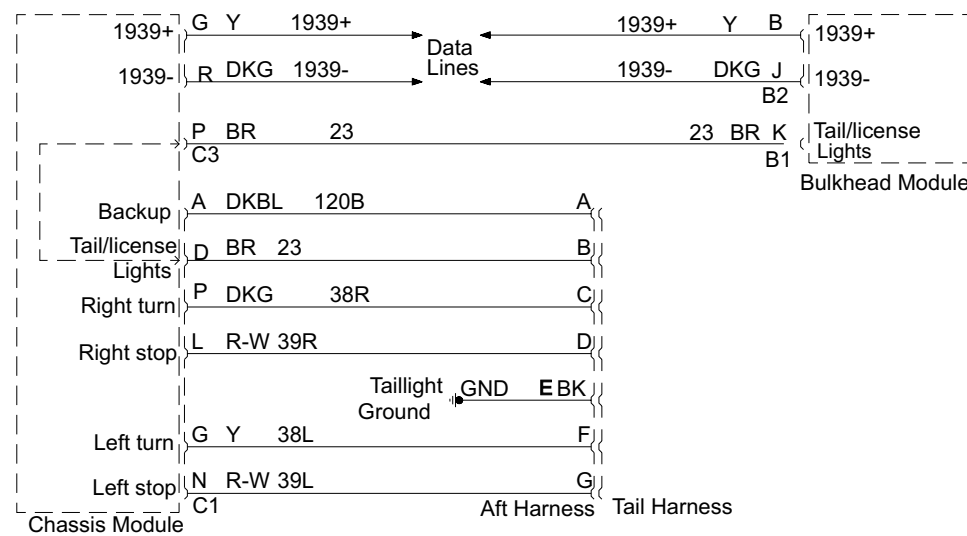

Rear Light Connector (separate stop/turn signal)
 Mating connector supplied with Chassis Packard Connector PAC 12110751
 Terminal supplied by Body Builder Packard Terminal PAC 15304719
 Freightliner Seal Part# 23-12497-282

Connector Pin	Signal Name	Signal Type	Circuit Color	Circuit Number
A	BackupLight	Output	DKBL	120B
B	TaillightsandLicenseLight	Output	BR	23
C	RightTurnSignalLight	Output	DKG	38R
D	RightStopLight	Output	R-W	39R
E	Ground	Ground	BK	GND
F	LeftTurnSignalLight	Output	Y	38L
G	LeftStopLight	Output	R-W	39L

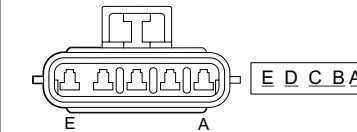

Mating connector supplied by Body Builder Packard Connector 12186400
 Terminal supplied by Body Builder Packard Terminal 12129497
 Freightliner Part# 23-13213-131

Rear Light Connector (combination stop/turn signal)

Connector Pin	Signal Name	Signal Type	Circuit Color	Circuit Number
A	BackupLight	Output	DKBL	120B
B	TaillightsandLicenseLight	Output	BR	23
C	LeftStop/TurnSignalLight	Output	R-W	39L
D	RightStop/TurnSignalLight	Output	R-W	39R
E	Ground	Ground	BK	GND

Lighting Outputs For Individual RearLights (Combination stop/turn signal)

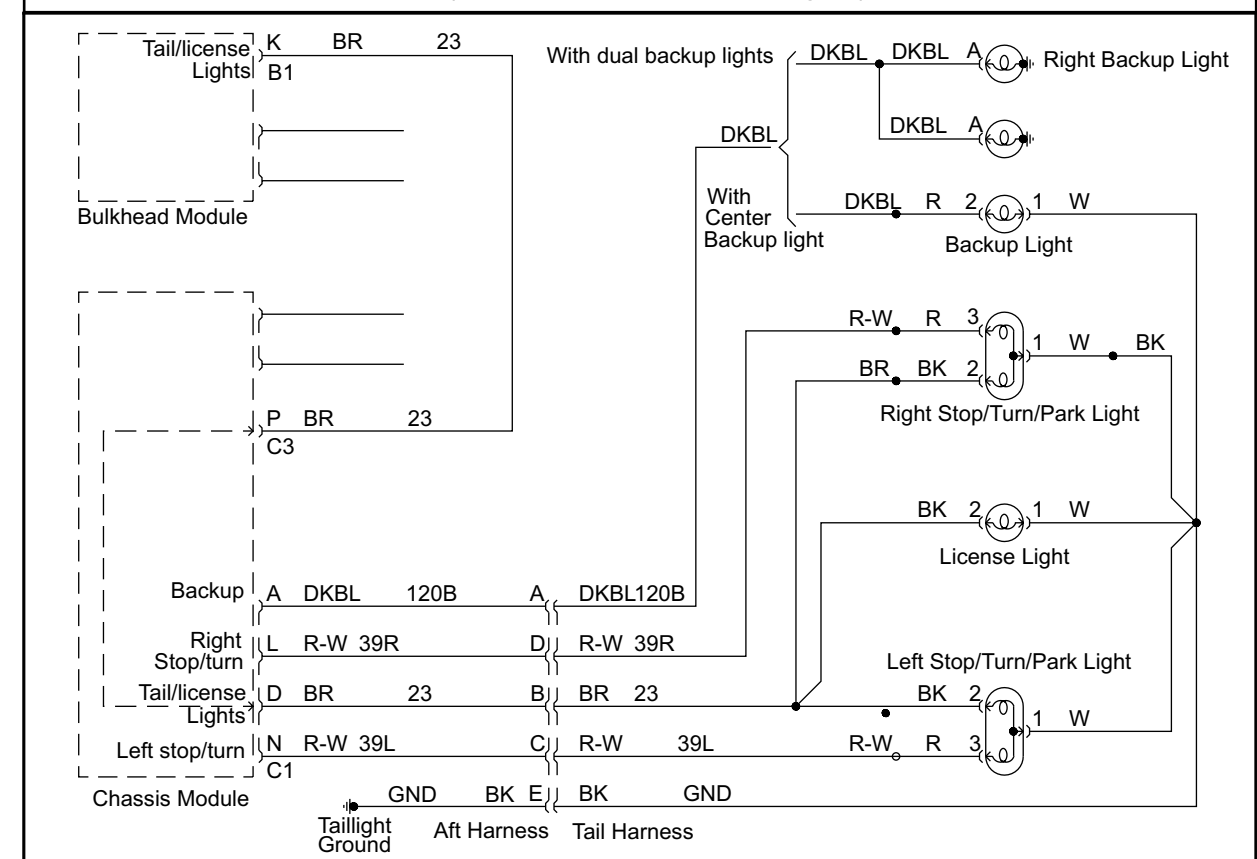

All Plugs viewed from Front

Transmission Interface Connector

Depending on the transmission that is installed in the vehicle, the transmission interface harness provides the VIW connection for the current generation of 1000/2000 series or 3000/4000 series electronic controls.

The transmission interface harness provides most of the optional I/O circuits and speedometer signal, in a conveniently located connector.

Connectors can be ordered in three locations using the options shown below.

There should be a green ribbon tape at the connector for easy locating and identification.

This reference guide does not illustrate electrical device interface design to the transmission interface connector. Refer to Allison Transmission documentation for feature and function specifications and illustration of specific electrical device interface design of each circuit.

Transmission Interface Connector

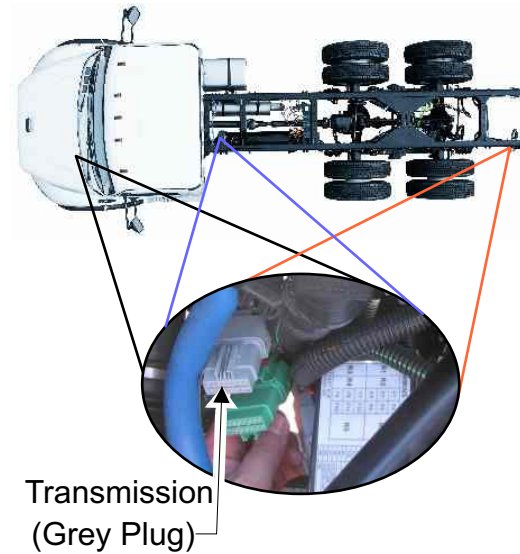

Transmission (Grey Plug)

Data Book Codes for the Transmission Interface Harness

Data Book Code	Description
34C-001	Transmission Interface Harness at the Frontwall
34C-002	Transmission Interface Harness at Back of Cab
34C-003	Transmission Interface at End of Frame

Transmission Interface (Gray Plug)

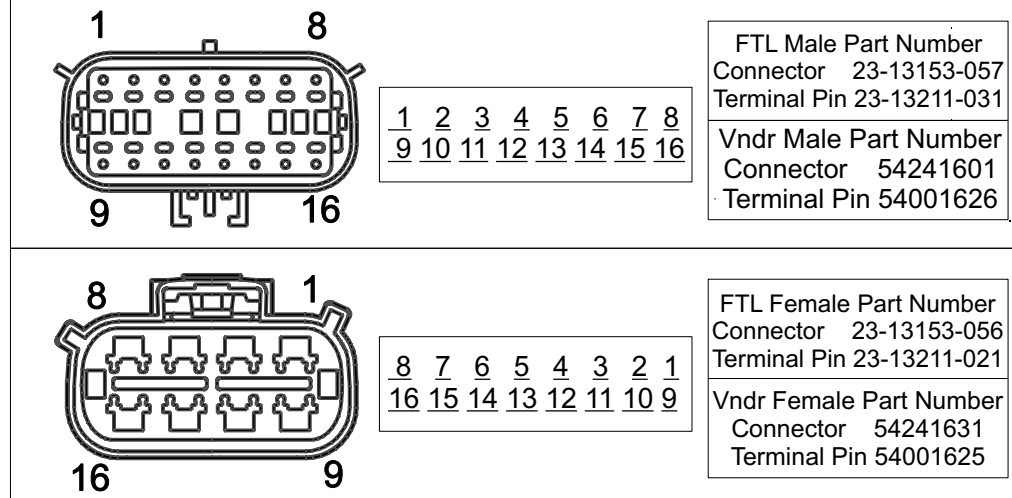

Pin No.	Freightliner Circuit No.	Allison Transmission n® Circuit No.	Allison Transmission Function †	
			1000/2000 Series	3000/4000 Series
1	232E	163	Ignition Signal	Ignition Signal
2	497C7 (O [‡])	150	PTO Enable	PTO Enable
3	497C8 (O)	113	–	Secondary Mode Indicator Range Indicator Engine Overspeed Indicator
4	497Y	103	Digital Ground	Digital Ground
5	497K (O)	125	Vehicle Speed Sensor	Vehicle Speed Sensor
6	497C4 (O)	105	Output Speed Indicator A	Output Speed Indicator A
7	497C3 (O)	145	Neutral Indicator for PTO Two-Speed Axle Enable	Neutral Indicator for PTO Two-Speed Axle Enable
8	497D3 (I [§])	143	PTO Enable	Direction Change Enable PTO Enable Reverse Enable
9	497C1 (O)	130	–	Engine Overspeed Indicator PTO Enable Secondary Mode Indicator
10	497D5 (I)	142	Secondary Mode Input	Auxiliary Hold Secondary Mode Input Two-Speed Axle Enable Automatic Neutral-Dual Input With Park Brake Auto Neutral-Dual Input With Service Brake Status Auxiliary Function Range Inhibit (special) Auto Neutral-Dual Input With Service Brake Status
11	497D6 (I)	101	Auxiliary Function Range Inhibit (standard)	Auxiliary Function Range Inhibit (standard) Automatic Neutral-Dual Input With Park Brake Shift Selector Transition Two-Speed Axle Enable Shift Selector Transition/Secondary Shift Schedule Auxiliary Function Range Inhibit (special)
12	497D10 (I)	117	–	Automatic Neutral-Single Input Direction Change Enable Reverse Enable Automatic Neutral-Dual Input With Park Brake Auto Neutral-Dual Input With Service Brake Status
13	497C6 (O)	164	Sump Retarder Temperature Indicator	Sump Retarder Temperature Indicator
14	497D1 (I)	123	3rd Lockup Pump Mode	4th Lockup Pump Mode Kickdown Direction Change Enable
15	497D4 (I)	122	3rd Lockup Pump Mode Transfer Case Low	4 th Lockup Pump Mode Refuse Packer Step Switch Reduced Engine Load at Stop
16	–	–	–	–

† When more than one function is listed, see the Allison Transmission Vocational Model Guide for the applicable function.

§§ Output



Engine Interface Connector

Freightliner provides an engine interface harness when an rpm control system is ordered for optional body builder features and PTO (power takeoff) applications.

The optional features provided by this harness include:

- Fast idle
- Increment/decrement
- Multiple fixed speeds
- Variable RPM title

Module 148 determines the type of remote engine throttle.

Module 163 determines the location of the interface connector.

Module 87L determines the interlock requirements.

There should be a tan ribbon tape at the connector for easy locating and identification.

Engine Interface Connector

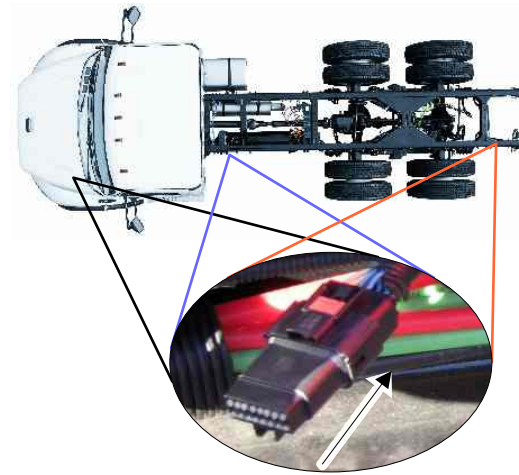

Engine (Black Plug)

Data Book Codes for Engine Remote Interface Harnesses (ERIH)	
Data Book Code	Description
148-070	ERIH With Fixed Single Speed
148-071	ERIH With Increment/Decrement
148-072	ERIH With Multiple Set Speeds
148-073	ERIH for Remote Throttle
148-074	ERIH Not Configured
163-001	ERIH at Back of Cab
163-002	ERIH at End of Frame
163-003	ERIH at End of Frame w/6-ft Harness
163-004	ERIH s in Engine Compartment
163-012	ERIH Inside the Cab Under the Dash Blunt Cut
163-006	ERIH Inside the Cab Under the Dash
87L-001	ERIH With Park Brake Interlock
87L-003	ERIH With Park Brake and Neutral Interlocks
87L-005	ERIH Without Interlocks

DD13 Interface				
Pin	Harness	Usage Description	Circuit #	CPC Pin Conn/Pin
1	Eng Control Dash	Dash Engine Control	483Z	4/2
2	Engine Control	Remote VSG Select	439U	2/9
3	Engine Control	Cruise Control On/Off Enable	492U	1/14
4	Engine Control	Cruise Control Set/Coast	483A	1/12
5	Engine Control	Cruise Control Resume/Accel	483B	1/16
6	Engine Control	Limiter 0	439V1	1/11
7	Engine Control	Limiter 1	439V2	2/11
8	Engine Control	Tachometer	483E	1/9
9	Engine Control	Throttle Inhibit	492Z	1/17
10	Engine Control	Remote Accelerator Select	483N	2/8
11	Engine Control	Variable Speed Governor	483C	3/4
12	Engine Control	+5V Sensor Supply	483D	3/3
13	Eng Control Dash	Dash Engine Control	492Y	4/2
14	Power Ignition	Dash Power	439A	2/3
15	Spare	---	-	-
16	Spare	---	-	-

Cummins Interface				
Pin	Harness	Usage Description	Circuit #	ECM Pin
1	Eng Control Dash	Engine RPM Chass	400G	62
2	Engine Control	Remote PTO	439U	94
3	Engine Control	CC/PTO On/Off Switch w/RPM	492U	90
4	Engine Control	CC/PTO Set w/RPM	483A	12
5	Engine Control	CC/PTO Resume w/RPM	483B	19
6	Engine Control	Max Operating Speed/Gov	483R	66
7	Spare	---	-	-
8	Engine Control	Tachometer	483E	30
9	Spare	---	-	-
10	Engine Control	Remote Throttle On/Off	483N	67
11	Engine Control	Remote Throttle Signal w/RPM	483C	63
12	Engine Control	Remote Throttle Power	483D	8
13	Engine Control	Eeng #1 Snsr Com Ground w/RPM	492Y	32
14	Spare	---	-	-
15	Spare	---	-	-
16	Spare	---	-	-

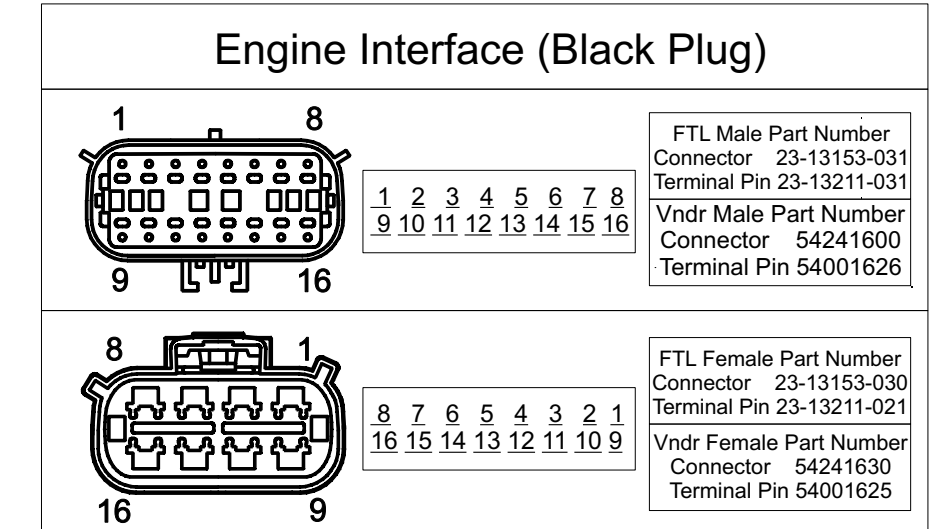

PTO Wire Harness Wiring

- Remote Throttle Return Must be Grounded thru Pin 1

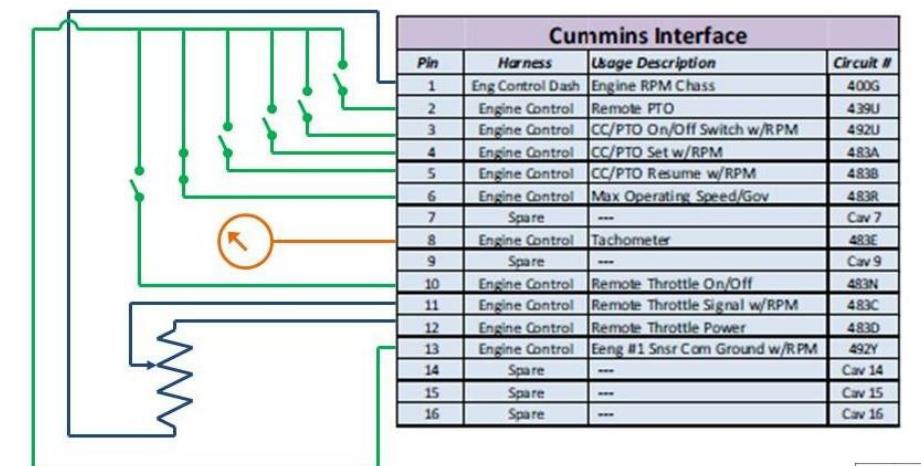

- All Switches MUST be Grounded thru Pin 13



Rev - B

PTO Installation Compatibility

All SmartPlex PTO controls employ a multiplexed dash mounted Smart Switch, PTO Control wiring, and air piping, which is driven by several different factors on the M2 and SD Platforms.

Factors include but are not limited to:

- Transmission type
- Transmission programming package
- PTO make and model, and interlock type

PTO controls are pre-wired specifically to match the transmission and PTO combination. For this reason data code combinations for Modules 372 and 362 are critical.

Module 372 specifies the Number and Type of PTO Controls

- Single or Dual controls
- Interlock Scheme (Park Brake Interlock, Neutral Interlock, Park Brake & Neutral Interlock)

Module 362 specifies which PTO will be installed. This can be specified two ways

- A factory installed PTO can be chosen (Contact your CAE representative for a quote)
- For "Customer Installed" data codes select from the options in the chart

If a 372 code other than 372-998 or 372-051 is specified, a corresponding 362 data code must be specified to ensure the correct wiring, PTO connector style, and air piping connections are in place.

The charts on this page are designed to help guide you through the compatibility process.

PTO Wiring can be found in module 885.



PTO Installation Compatibility

Customer Installed PTO Compatibility Chart

Mod 362 PTO Options	Option Description	Electric over Air Shift PTO Control		Electric Over Hydraulic Shift PTO Control
		All Manual Transmissions	Allison Automatic Transmissions w/PTO provisions	Allison Automatic Transmissions w/PTO provisions
362-801	MUNCIE RS4 SERIES REAR MOUNT PTO, CUSTOMER INSTALLED	X	X	
362-1T7	CHELSEA 221 SERIES, CUSTOMER INSTALLED PTO	X	X	
362-1BU	CHELSEA 230/231/236 SERIES, CUSTOMER INSTALLED PTO	X	X	
362-1M2	CHELSEA 236 SERIES, CUSTOMER INSTALLED PTO	X	X	
362-802	CHELSEA 442 SERIES, CUSTOMER INSTALLED PTO	X	X	
362-1T6	CHELSEA 489 SERIES, CUSTOMER INSTALLED PTO	X	X	
362-1PB	CHELSEA 541 SERIES REAR MOUNT, CUSTOMER INSTALLED PTO	X	X	
362-1T8	CHELSEA 812 SERIES, CUSTOMER INSTALLED PTO	X	X	
362-805	MUNCIE 82 SERIES, CUSTOMER INSTALLED PTO	X	X	
362-803	MUNCIE SERIES CS6 WITH ELEC/AIR CONTROLS, CUSTOMER INSTALLED PTO	X	X	
362-800	MUNCIE SERIES CS8, CUSTOMER INSTALLED PTO	X	X	
362-040	MUNCIE SERIES TG6 & TG8, CUSTOMER INSTALLED PTO	X	X	
362-1U0	MUNCIE SERIES TG6, CUSTOMER INSTALLED PTO	X	X	
362-1U1	MUNCIE SERIES TG8, CUSTOMER INSTALLED PTO	X	X	
362-1BV	CHELSEA 270 SERIES, CUSTOMER INSTALLED PTO			X
362-1DV	CHELSEA 277 SERIES WITH REMOTE SOLENOID, CUSTOMER INSTALLED PTO			X
362-035	CHELSEA 277 SERIES, CUSTOMER INSTALLED PTO			X
362-145	CHELSEA PTO - CHL340SFAHX G5XD			X
362-158	CUSTOMER INSTALLED MUNCIE CS10 SERIES PTO			X
362-807	CUSTOMER INSTALLED MUNCIE 41 SERIES PTO			X
362-157	MUNCIE SERIES CS20, CUSTOMER INSTALLED PTO			X
362-804	MUNCIE SERIES CS6 WITH ELEC/HYD CONT, CUSTOMER INSTALLED PTO			X

Factory installed PTO's are available and can also be selected (Contact CAE representative for quotes and availability)



PTO Controls

PTO Controls

All SmartPlex PTO controls employ a Multiplexed dash mounted Smart Switch. PTO Control wiring and air piping is driven by several different factors on the M2 and SD Platforms.

Factors include but are not limited to:

- Transmission type, Transmission programming package,
- PTO make and model, PTO Interlock type

PTO controls are pre-wired specifically to match the transmission and PTO combination.

For this reason data code combinations for Modules 372 and 362 are critical.

Module 372 specifies the Number and Type of PTO Controls

- Single or Dual controls
- Interlock Scheme (Park Brake Interlock, Neutral Interlock, Park Brake & Neutral Interlock)

Module 362 specifies which PTO will be installed. This can be specified two ways

- A factory installed PTO can be chosen (Contact CAE representative for quote)
- For "Customer Installed" data codes select from the options in Chart Below

If a 372 code other than 372-998 or 372-051 is specified, a corresponding 362 data code must be specified to ensure the correct wiring, PTO connector style, and air piping connections are in place.

The charts on this page are designed to guide you through the compatibility process. 26-20720-004



Factory Installed PTO Control Compatibility Chart

Mod 372 PTO Control Options	Option Description	PTO Installation		Electric over Air Shift PTO Control			Electric Over Hyd Shift PTO Control		Controls		Safety Interlocks		Availability	
		Factory Installed	Customer Installed	Manual Transmissions	AGS2 Transmissions	Allison Automatic Transmissions w/PTO provisions	Allison Automatic Transmissions w/PTO provisions	Single Dash Switch	Dual Dash Switches	Park Brake Interlock	Neutral Interlock	Data Book / Spec Pro Published	Unpublished - Avail via Price Quote	
372-035	(1) DASH MTD PTO SWITCH W/IND LAMP	X		X	X	X	X	X					X	
372-063	(1) DASH MTD PTO SWITCH W/IND LAMP FOR CUST INST PTO		X	X	X	X	X	X					X	
372-036	(1) DASH MTD PTO SWITCH W/IND LAMP - PK BRK INTERLOCK	X		X	X	X	X	X		X			X	
372-065	(1) DASH MTD PTO SWITCH W/IND LAMP - PK BRK INTERLOCK FOR CUST INST PTO		X	X	X	X	X	X		X			X	
372-037	(1) DASH MTD PTO SWITCH W/IND LAMP - NEUT INTERLOCK	X				X	X	X			X		X	
372-067	(1) DASH MTD PTO SWITCH W/IND LAMP - NEUT INTERLOCK FOR CUST INST PTO		X			X	X	X			X		X	
372-043	(1) DASH MTD PTO SWITCH W/IND LAMP - PK BRK & NEUT INTERLOCK	X				X	X	X		X	X		X	
372-073	(1) DASH MTD PTO SWITCH W/IND LAMP - PK BRK & NEUT INTERLOCK FOR CUST INST PTO		X			X	X	X		X	X		X	
372-058	(1) DASH MTD PTO SWITCH W/IND LAMP WITH PDI MODIFICATION TO INCREASE ENGINE RPM TO HIGH IDLE WHEN PTO IS ENGAGED	X		X	X			X						X
372-068	(1) DASH MTD PTO SWITCH W/IND LAMP WITH PDI MODIFICATION TO INCREASE ENGINE RPM TO HIGH IDLE WHEN PTO IS ENGAGED FOR CUST INST PTO		X	X	X			X						X
372-044	(1) DASH MTD PTO SWITCH W/IND LAMP FOR AGS2 TRANS - STATIONARY MODE	X			X			X						X
372-066	(1) DASH MTD PTO SWITCH W/IND LAMP FOR AGS2 TRANS - STATIONARY MODE FOR CUST INST PTO		X		X			X						X
372-045	(1) DASH MTD PTO SWITCH W/IND LAMP FOR AGS2 TRANS - MOBILE MODE	X			X			X						X
372-064	(1) DASH MTD PTO SWITCH W/IND LAMP FOR AGS2 TRANS - MOBILE MODE FOR CUST INST PTO		X		X			X						X
372-051	CUSTOMER FURNISHED AND INSTALLED PTO CONTROLS **		X	X	X	X	X							X
372-060	(2) DASH MTD PTO SWITCHES W/IND LAMPS	X		X	X	X	X		X					X
372-069	(2) DASH MTD PTO SWITCHES W/IND LAMPS FOR CUST INST PTO		X	X	X	X	X		X					X
372-054	(2) DASH MTD PTO SWITCHES W/IND LAMPS - PK BRK INTERLOCKS	X		X	X	X	X		X	X				X
372-072	(2) DASH MTD PTO SWITCHES W/IND LAMPS - PK BRK INTERLOCKS FOR CUST INST PTO		X	X	X	X	X		X	X				X
372-062	(2) DASH MTD PTO SWITCHES W/IND LAMPS - NEUT INTERLOCKS	X				X	X		X		X			X
372-071	(2) DASH MTD PTO SWITCHES W/IND LAMPS - NEUT INTERLOCKS FOR CUST INST PTO		X			X	X		X		X			X
372-061	(2) DASH MTD PTO SWITCHES W/IND LAMPS - PK BRK & NEUT INTERLOCKS	X				X	X		X	X	X			X
372-070	(2) DASH MTD PTO SWITCHES W/IND LAMPS - PK BRK & NEUT INTERLOCKS FOR CUST INST PTO		X			X	X		X	X	X			X
372-998	NO PTO CONTROLS ***			X	X	X	X							X

(X) Designates availability of PTO control/ PTO control type and transmission

** If customer is supplying their own controls and does not require factory installed parts 372-051 should be specified to notify the plant to route clearance for pto Install

*** 372-998 should be specified only when a PTO will not be needed or added in the future. (no routing provision will be done)

PTO Air Control Schematics

Schematics are for reference only, see the following modules for vehicle specific configurations.

- Wiring - module 885
- Airing - module 372
- Factory PTO - Module 362

PTO Air Control Schematics

PTO Switch Control Schematic

Module: 885

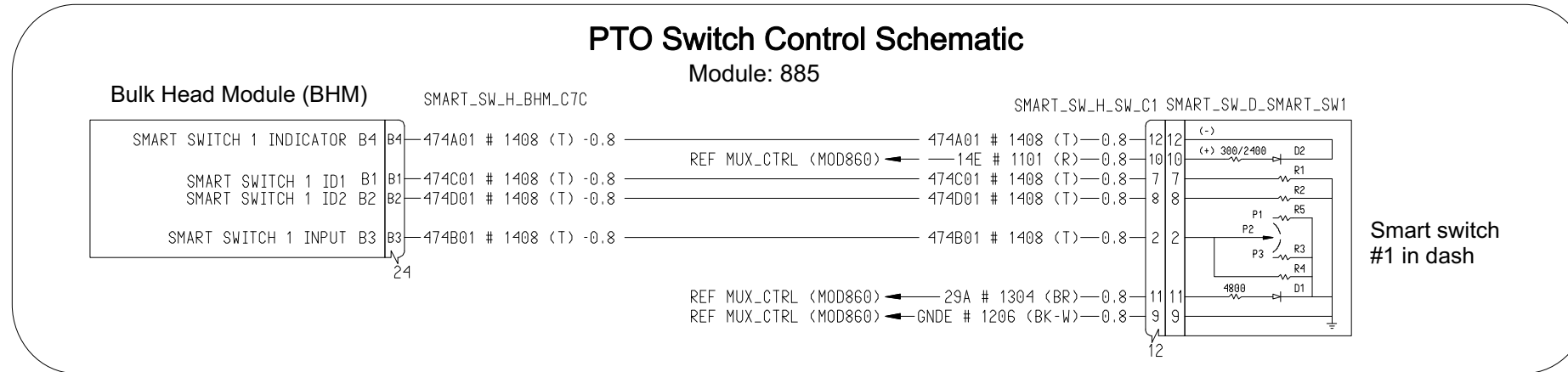

PTO Air Schematics

Module: 372

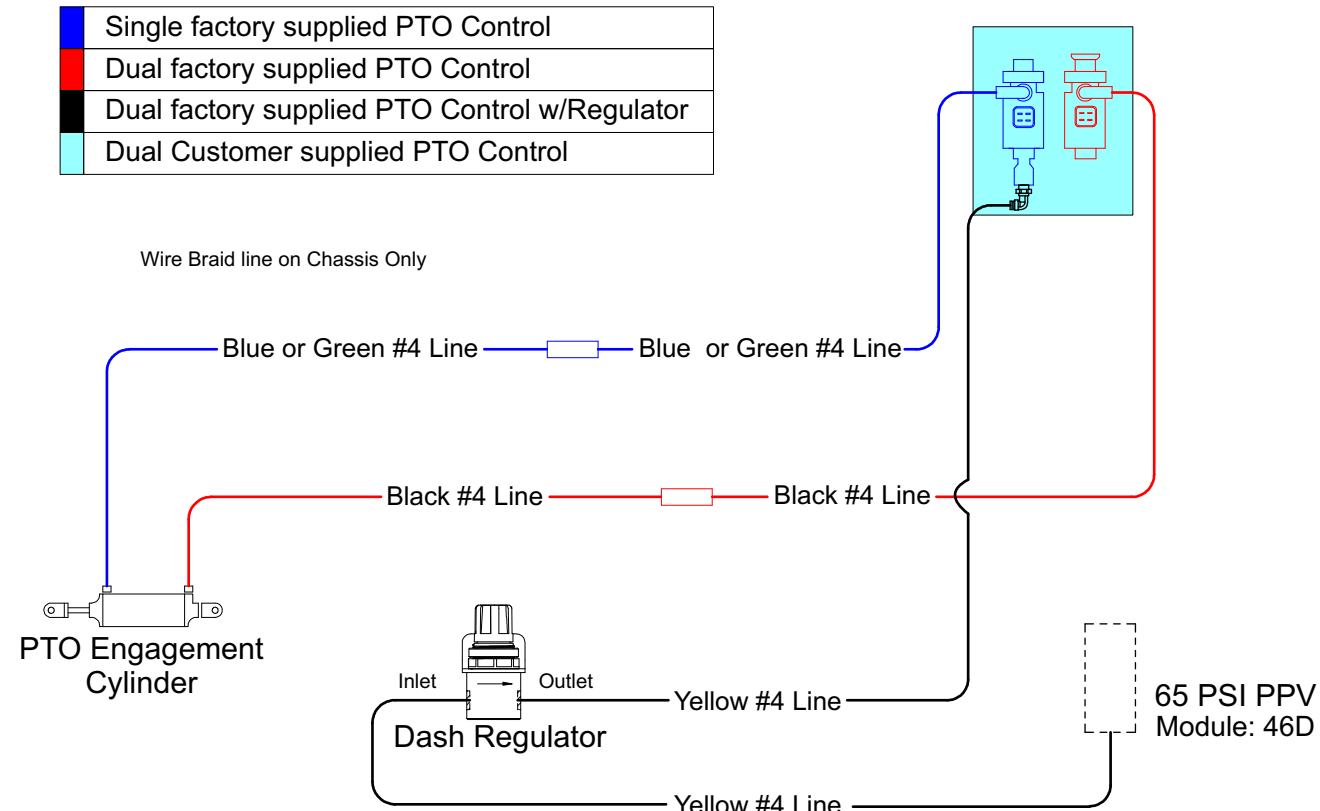

CHASSIS MODULE

ABS_H_CHM_C5C

PTO Electrical Schematic

Module: 885

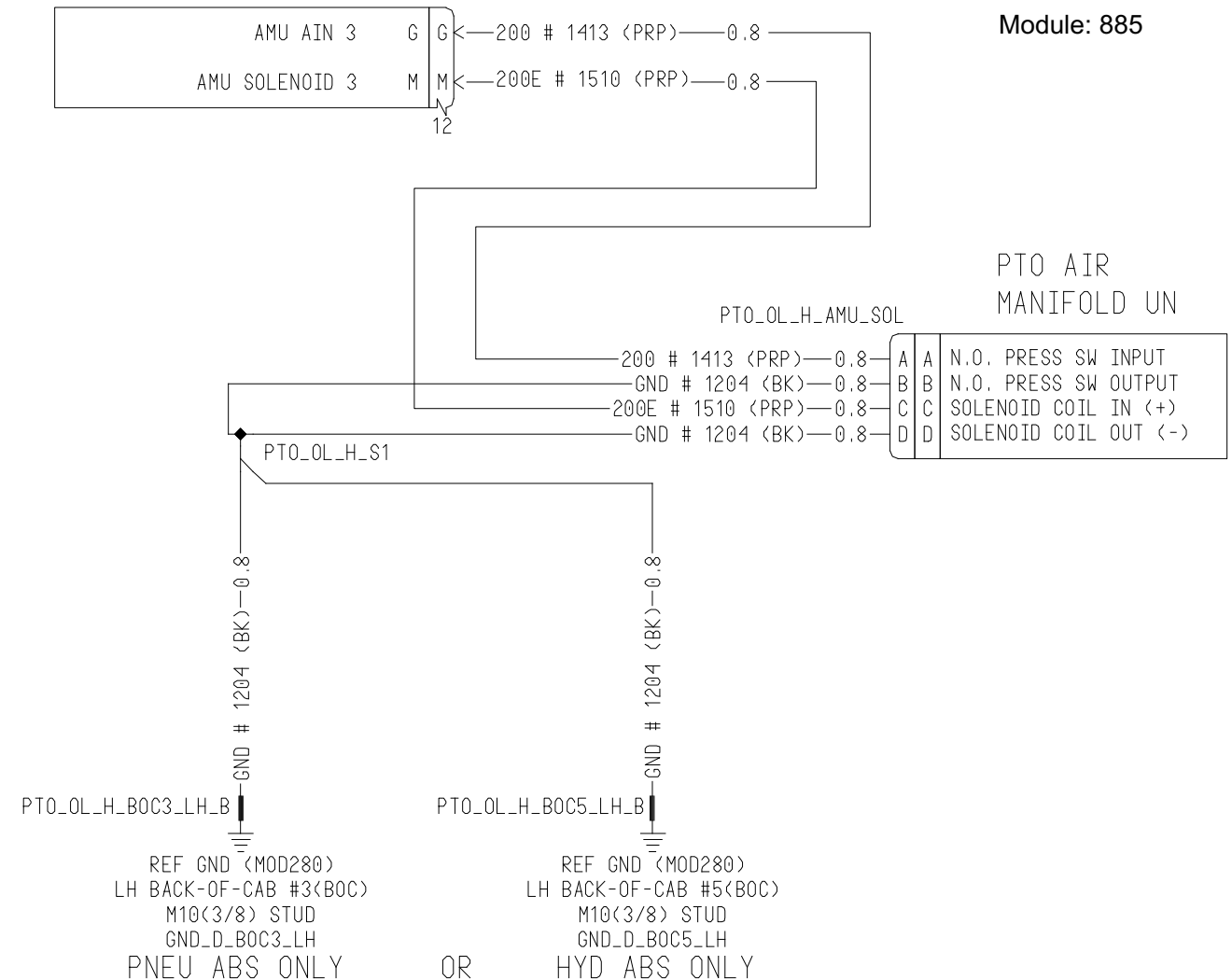

PTO Electric Control Schematics

PTO Electric Control Schematics

Schematics are for reference only, see the following modules for vehicle specific configurations.

- Wiring - module 885
- Airing - module 372
- Factory PTO - Module 362

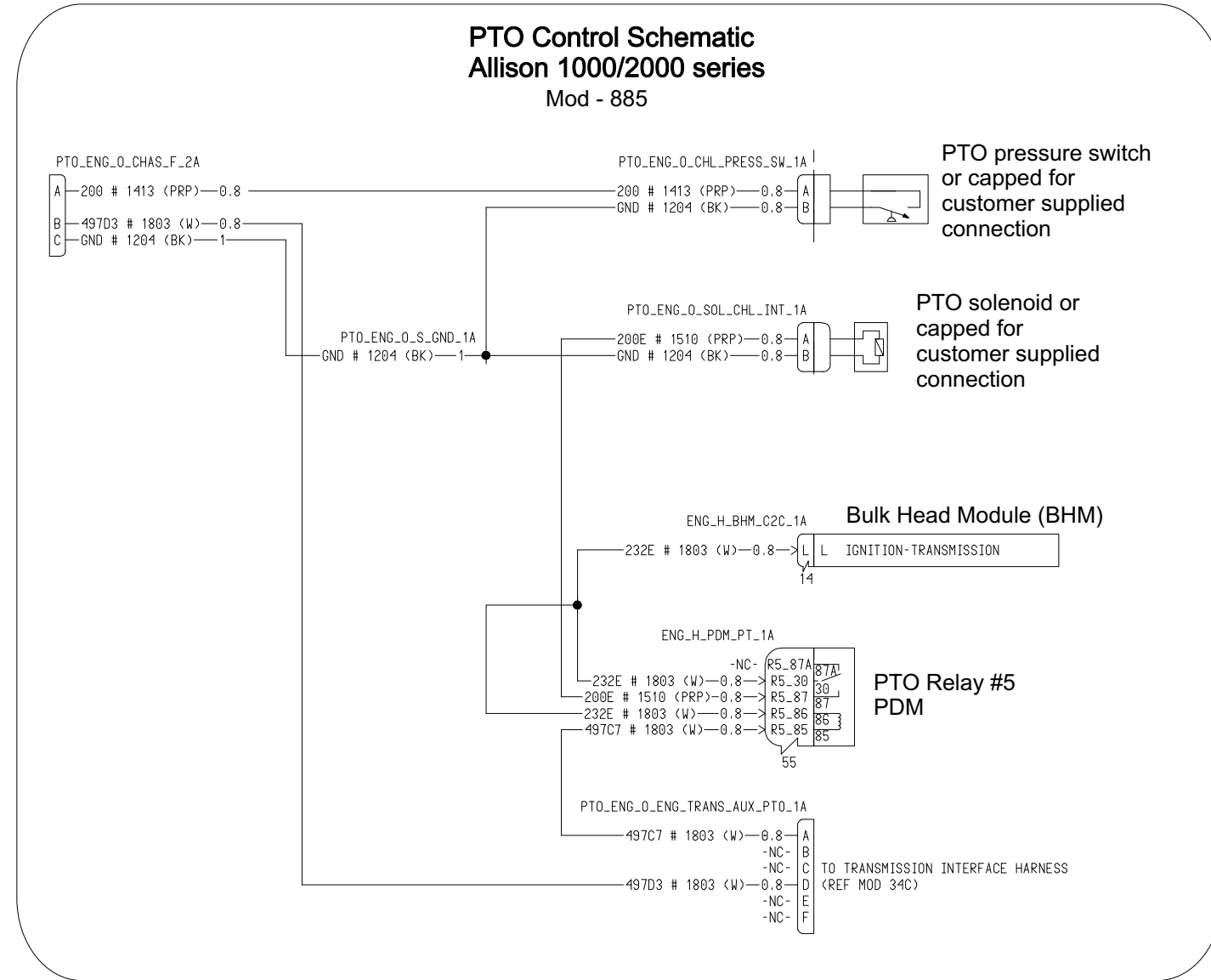
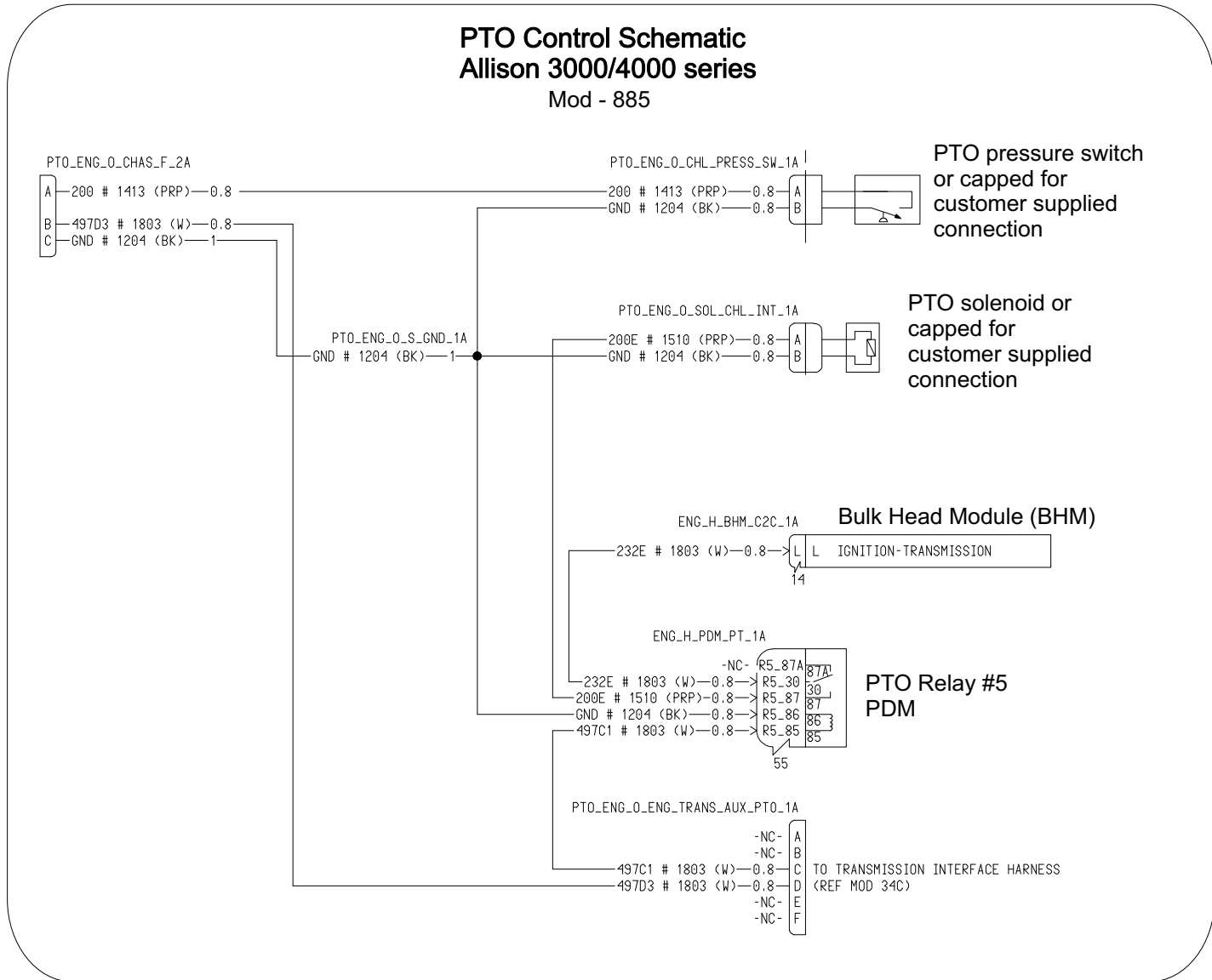
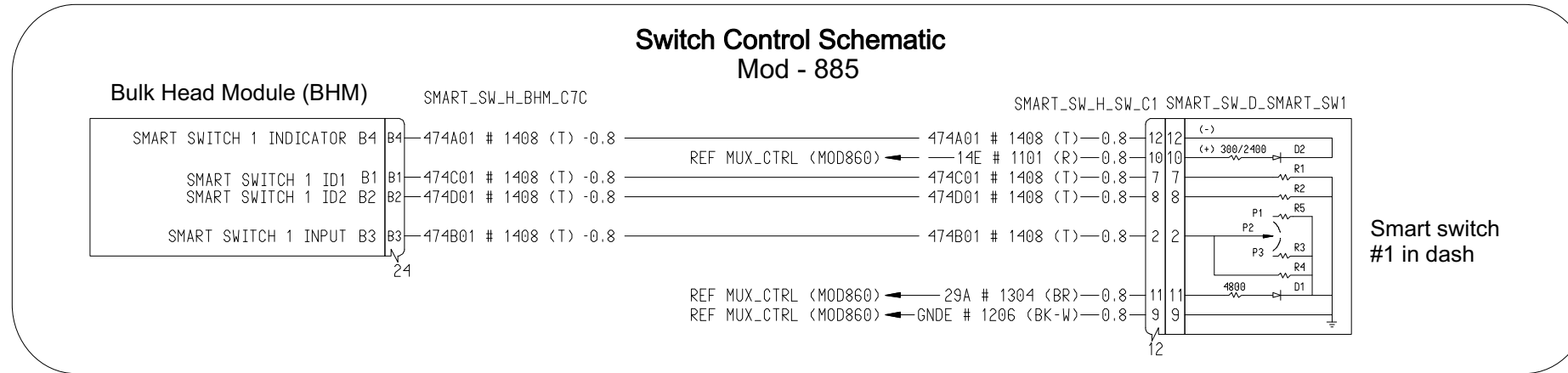

Remote Start/Stop Controls

The remote start stop feature is available but requires a few interlocks for the safety of the operators.

- Transmission neutral interlock
- Hood switch
- PTO switch in the dash

Schematics are for reference only, see the following modules for vehicle specific configurations.

- Wiring - module 157

Remote Start Stop Controls

157-007 MANUAL REMOTE ENGINE START/STOP WITH PTO RE-ENGAGE

- Available only with Allison or Eaton Fuller RT/O/X, FM, FR/FRO, RTLO, UltraShift or UltraShift Plus transmissions.
- Available only in combination with DC 99C-013 2013 ONBOARD DIAGNOSTICS/2010 EPA/CARB/GHG14
- Requires one of the following:
 - DC 372-043 (1) DASH MOUNTED PTO SWITCH WITH INDICATOR LAMP - PARK BRAKE AND NEUTRAL INTERLOCK
 - DC 372-073 (1) DASH MOUNTED PTO SWITCH WITH INDICATOR LAMP - PARK BRAKE AND NEUTRAL INTERLOCK FOR CUSTOMER INSTALLED PTO
- Requires DC 018-002 AIR BRAKE PACKAGE

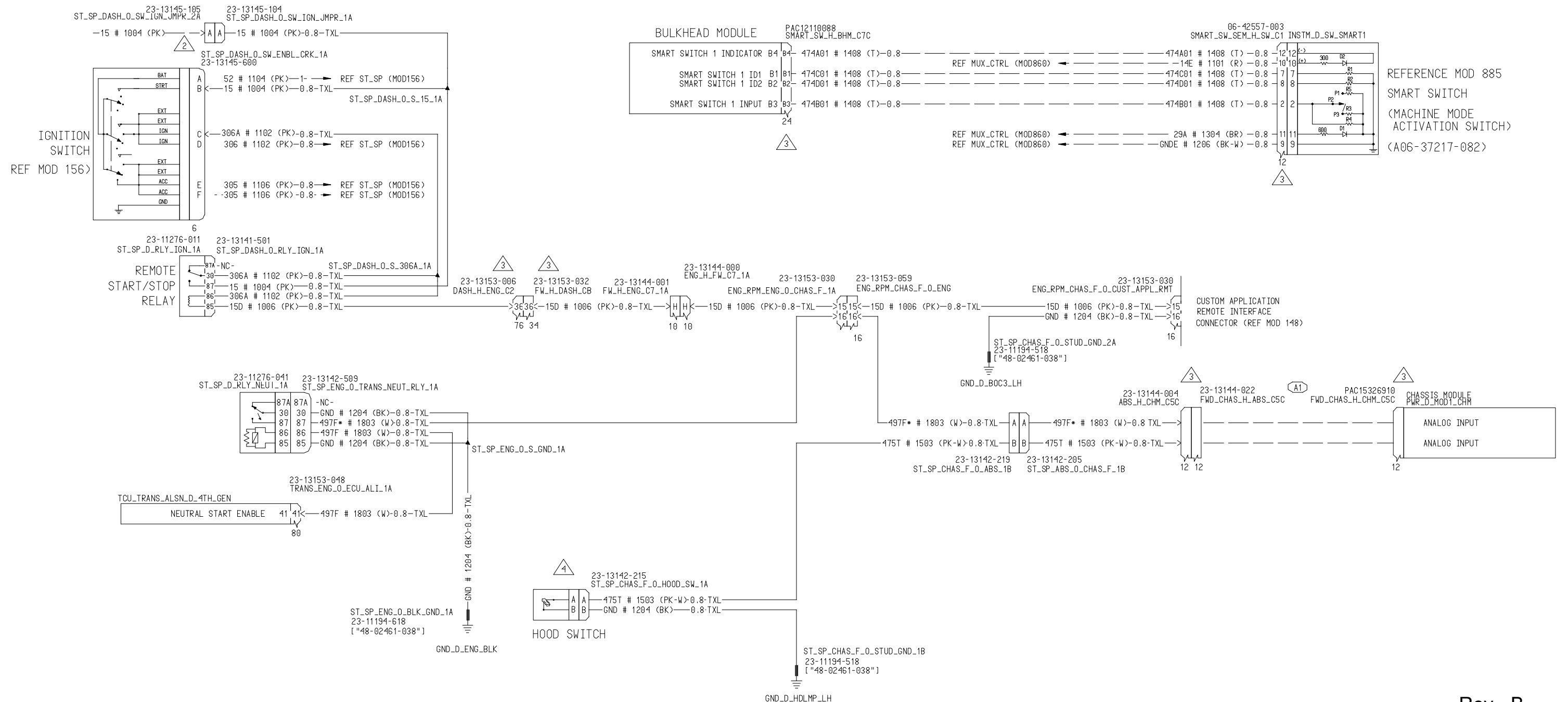



VDR Prep Information

The VDR Prep Harness comes standard with all SmartPlex vehicles that require NFPA 1901 compliant seat options
 756-1E7 / 756-1F2 and or 760-1E8 / 760-1E9 / 760-1F0
 760-1E7 / 760-1F1 / 760-1BX / 760-014 / 760-997

VDR Prep Information

Reference Module 74F for wiring details and schematics

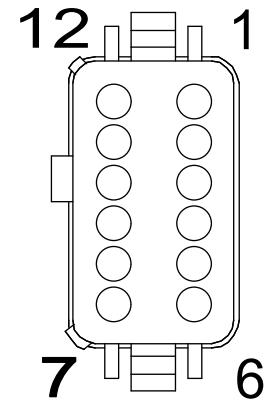

DRIVER SEATBELT BUCKLE	1	204B #2104 (T-W)	_____
DRIVER SEAT OCCUPY	12	432E #2010 (T-W)	_____
FRONT PASS SEATBELT BUCKLE	2	204C #2104 (T-W)	_____
FRONT PASS SEAT OCCUPY	11	432F #2010 (T-W)	_____
RR DRIVER SEATBELT BUCKLE	3	204D #2104 (T-W)	_____
RR DRIVER SEAT OCCUPY	10	432G #2010 (T-W)	_____
RR CENTER SEATBELT BUCKLE	4	204E #2104 (T-W)	_____
RR CENTER SEAT OCCUPY	9	432H #2010 (T-W)	_____
PP PASS SEATBELT BUCKLE	5	204F #2104 (T-W)	_____
RR PASS SEAT OCCUPY	8	432J #2010 (T-W)	_____
OPT PASS SEATBELT BUCKLE	6	204G #2104 (T-W)	_____
OPT PASS SEAT OCCUPY	7	432K #2010 (T-W)	_____

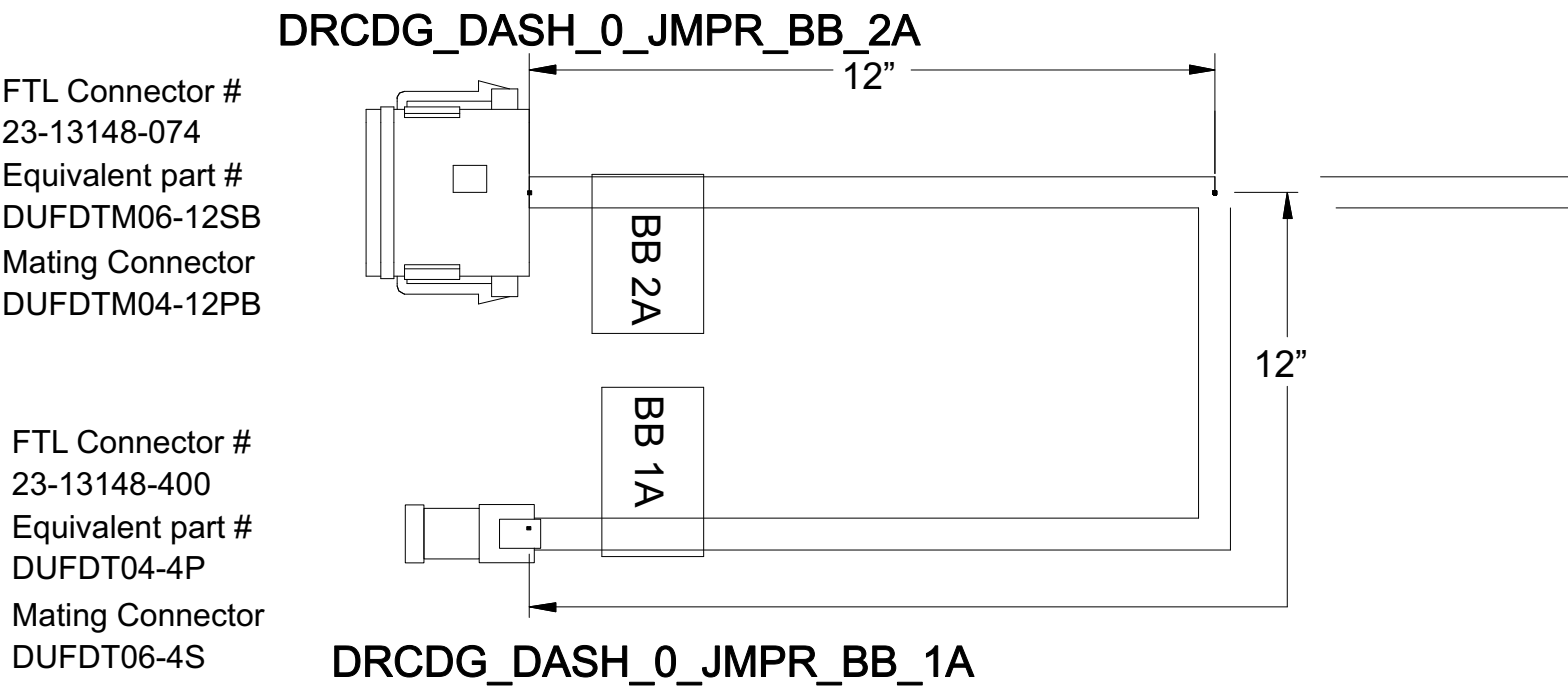
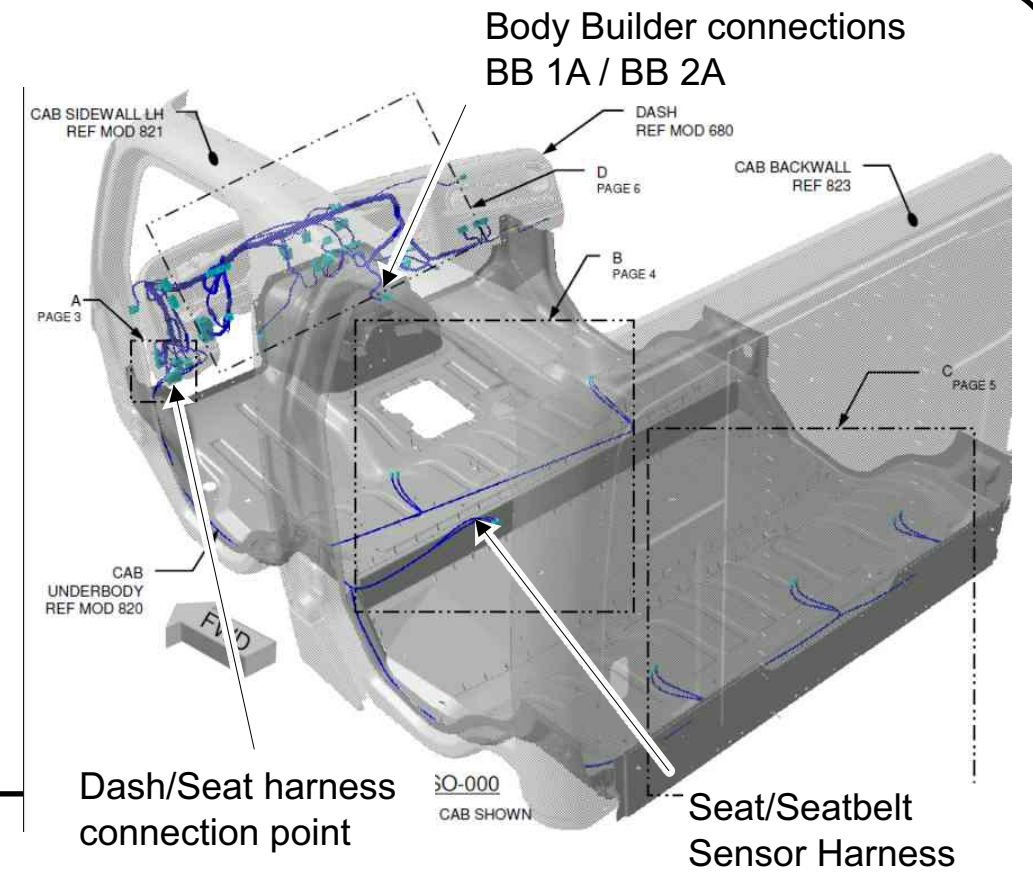

FTL Connector # 23-13148-074
 Equivalent part # DUFDTM06-12SB
 Mating Connector DUFDTM04-12PB

FTL Connector # 23-13148-400
 Equivalent part # DUFDT04-4P
 Mating Connector DUFDT06-4S

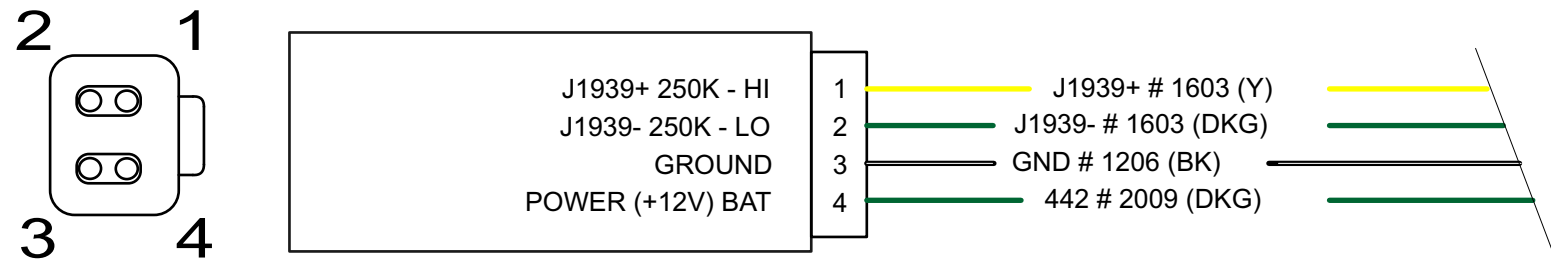
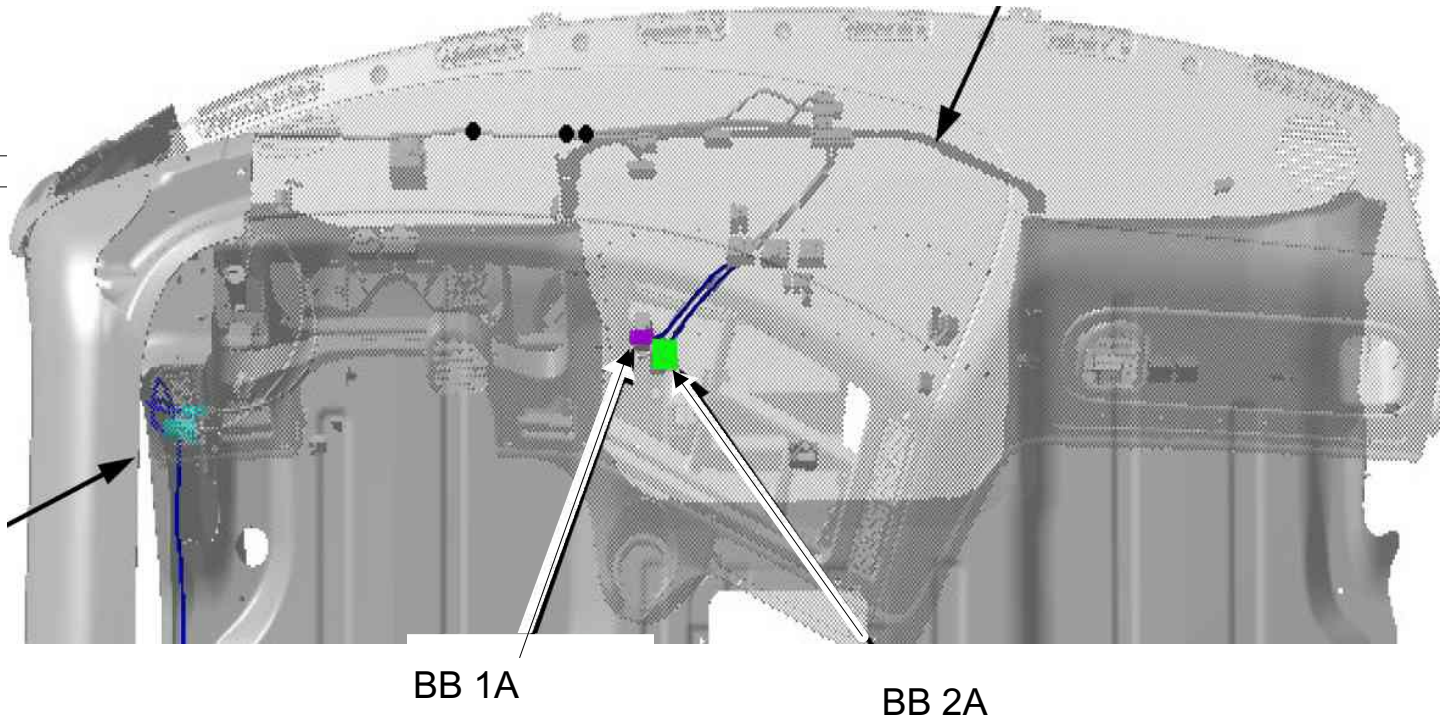

The VDR prep harness supplies a centrally located EDR black box connection under center of dash and includes all the connections needed for connection to the primary J1939 250K compliant VDR / EDR Units (see next page).

Rev - B

VDR Connections



[Http://www.weldoninc.com](http://www.weldoninc.com)

Weldon Vehicle Data Recorder to FTL Harness

Connector "B DTM06-12SB" to FTL Connector *DRCDG_DASH_0_vdr_2A*

I	INPUT	TYPE	BB2A Pin	INPUT	TYPE
1	Seat Belt 1 Status	Gnd/Batt	1	DRIVER SEATBELT BUCKLE	Gnd
2	Seat Belt 2 Status	Gnd/Batt	2	FRONT PASS SEATBELT BUCKLE	Gnd
3	Seat Belt 3 Status	Gnd/Batt	3	RR DRIVER SEATBELT BUCKLE	Gnd
4	Seat Belt 4 Status	Gnd/Batt	4	RR CENTER SEATBELT BUCKLE	Gnd
5	Seat Belt 5 Status	Gnd/Batt	5	PP PASS SEATBELT BUCKLE	Gnd
6	Seat Belt 6 Status	Gnd/Batt	6	OPT PASS SEATBELT BUCKLE	Gnd
7	Occupancy 6 status	Gnd/Batt	7	OPT PASS SEAT OCCUPY	Gnd
8	Occupancy 5 status	Gnd/Batt	8	RR PASS SEAT OCCUPY	Gnd
9	Occupancy 4 status	Gnd/Batt	9	RR CENTER PASS SEAT OCCUPY	Gnd
10	Occupancy 3 status	Gnd/Batt	10	RR DRIVER PASS SEAT OCCUPY	Gnd
11	Occupancy 2 status	Gnd/Batt	11	FRONT PASS SEAT OCCUPY	Gnd
12	Occupancy 1 status	Gnd/Batt	12	DRIVER SEAT OCCUPY	Gnd

Connector "A DTM06-12SA" to FTL Connector *DRCDG_DASH_0_VDR_1A*

I	INPUT	TYPE	BB2A Pin	INPUT	TYPE
1	Park Brake Status	Gnd/Batt	N/R	Supplied by J1939	Hi/Lo
2	Service Brake	Gnd/Batt	N/R	Supplied by J1939	Hi/Lo
3	E-master Status	Gnd/Batt	N/R	Body Builder Supplied (optional)	Gnd/Batt
4	CAN 2 – Lo	Lo	N/R	Body Builder Supplied (optional)	Lo
5	CAN 1 – Lo	Lo	2	J1939 - _ LO (250K)	Lo
6	V-MUX – B	Lo	VDR	Body Builder Supplied	Lo
7	V-MUX – A	Hi	VDR	Body Builder Supplied	Hi
8	CAN 1 – Hi	Hi	1	J1939 + _ HI (250K)	Hi
9	CAN 2 – Hi	Hi	N/R	Body Builder Supplied (optional)	Hi
10	System Power	Vbatt	4	POWER (+12V) BAT	Vbatt
11	Red Indicator	Gnd (Out)	N/R	Body Builder Supplied (optional)	Gnd (Out)
12	System Ground	GND	3	GROUND	GND

For M2 Models Service brake and ABS signals are broadcasting via J1939. The Weldon V-Mux VDR can accept M2 information via J1939 (250K) connection therefore no additional hard wiring is required with this harness.

VDR Connections to SmartPlex

813-1C0 NFPA VEHICLE DATA RECORDER AND SEATBELT DISPLAY

813-1C1 - NFPA VEHICLE DATA RECORDER AND SEATBELT DISPLAY WITH DETROIT VIRTUAL TECHNICIAN REMOTE ENGINE DIAGNOSTICS

813-1C2 - NFPA VEHICLE DATA RECORDER & SEATBELT DISPLAY W/DETROIT VIRTUAL TECH VISIBILITY PKG: REMOTE ENGINE DIAG W/WEB ACCESS, ENGINE & IFTA/IRP REPORTS & LOCATION DATA

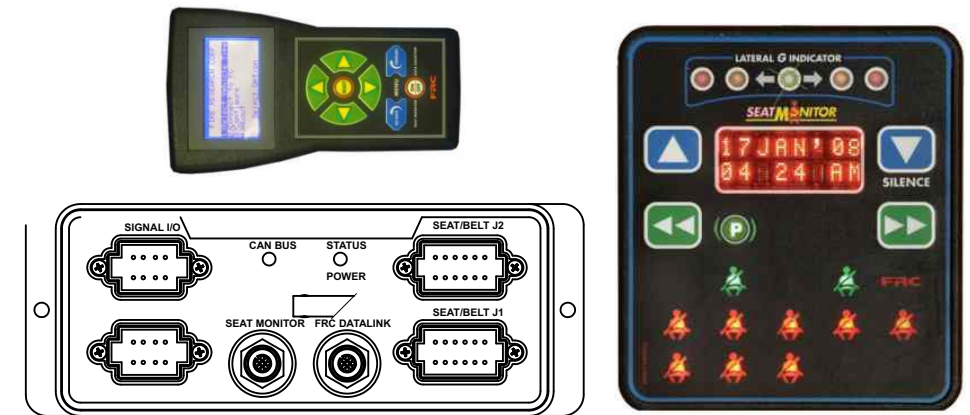

[Http://www.fireresearch.com](http://www.fireresearch.com)

FRC Vehicle Data Recorder to FTL Harness

Connector "Seat/Belt J1 DT06-12S" to FTL Connector *DRCDG_DASH_0_JMPR_BB_2A*

I	INPUT	TYPE	BB2A Pin	INPUT	TYPE
12	Seat Belt 1 Status	Gnd/Batt	1	DRIVER SEATBELT BUCKLE	Gnd
11	Seat Belt 2 Status	Gnd/Batt	2	FRONT PASS SEATBELT BUCKLE	Gnd
10	Seat Belt 3 Status	Gnd/Batt	3	RR DRIVER SEATBELT BUCKLE	Gnd
9	Seat Belt 4 Status	Gnd/Batt	4	RR CENTER SEATBELT BUCKLE	Gnd
8	Seat Belt 5 Status	Gnd/Batt	5	PP PASS SEATBELT BUCKLE	Gnd
7	Seat Belt 6 Status	Gnd/Batt	6	OPT PASS SEATBELT BUCKLE	Gnd
6	Occupancy 6 status	Gnd/Batt	7	OPT PASS SEAT OCCUPY	Gnd
5	Occupancy 5 status	Gnd/Batt	8	RR PASS SEAT OCCUPY	Gnd
4	Occupancy 4 status	Gnd/Batt	9	RR CENTER PASS SEAT OCCUPY	Gnd
3	Occupancy 3 status	Gnd/Batt	10	RR DRIVER PASS SEAT OCCUPY	Gnd
2	Occupancy 2 status	Gnd/Batt	11	FRONT PASS SEAT OCCUPY	Gnd
1	Occupancy 1 status	Gnd/Batt	12	DRIVER SEAT OCCUPY	Gnd

Connector "POWER/DATABUS DT06-8SA" to FTL Connector *DRCDG_DASH_0_JMPR_BB_1A*

	INPUT	TYPE	BB2A Pin	INPUT	TYPE
1	Supply + (Battery)	Batt	4	Vbatt	Vbatt
2	Supply - (GND)	Gnd	3	Ground	Gnd
3	Ignition	IGN (12V)	N/R	Body Builder Supplied	IGN (+12V)
4	Parking Brake Signal	Gnd/Batt	N/R	Supplied by J1939	Hi/Lo
5	Master Optical Warning	Gnd/Batt	N/R	Body Builder Supplied (optional)	
6	J1939 (shield)	Gnd	N/R	Not Required	
7	J1939 (-)	Lo	2	J1939 - _ LO (250K)	Lo
8	J1939 (+)	Hi	1	J1939 + _ HI (250K)	Hi

Rev - B

Snow Plow Lamp (304-038, 304-039)

Factory installed provision for snow plow light control that provides an in dash control switch and wiring for customer installed plow lights.

When the snow plow lamp switch in the cab is activated, the truck headlights are turned off and the headlight controls will operate the customer installed headlights. Low beams will be off with high beam request.

Note: Power to snow plow module typically provided through fuses F3 and F4 located in the Power Distribution Module.

Data code 304-038 provides a single connector and switch for plow mounted headlights.

Data code 304-039 provides dual connectors and switch for hood mounted headlights.

The plow light connector should have a blue ribbon tape at the connectors for easy location and identifications.

Snow Plow Lamps

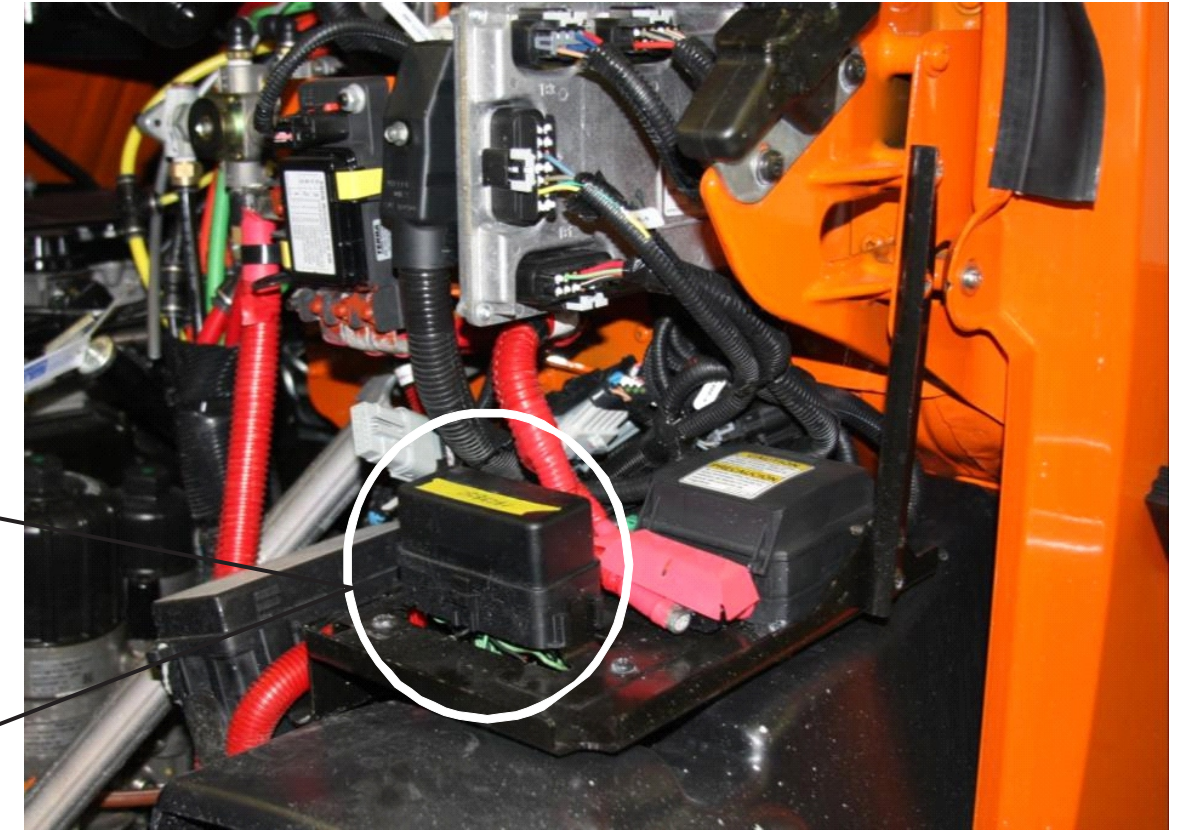

304-039 Snow Plow Headlight Dual Connector (LH Side)

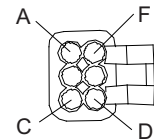

Mating connector supplied with Chassis
 Packard Connector PAC 12052848
 Terminal supplied by Body Builder
 Packard Terminal PAC 12048074
 Packard Seal Part# PAC 12059168

Connector Pin	Signal Name	Signal Type	Circuit Color	Circuit Number	Amperage
A	High Beam	Output	LTG	462K	30
B	Ground	Ground	BK	462C	-
C	Low Beam	Output	LTG	462J	25
D	Marker Lamp	Output	BR	102C	10
E	Ground	Ground	BK	GND	-
F	Left Turn Signal	Output	Y	38LP	-

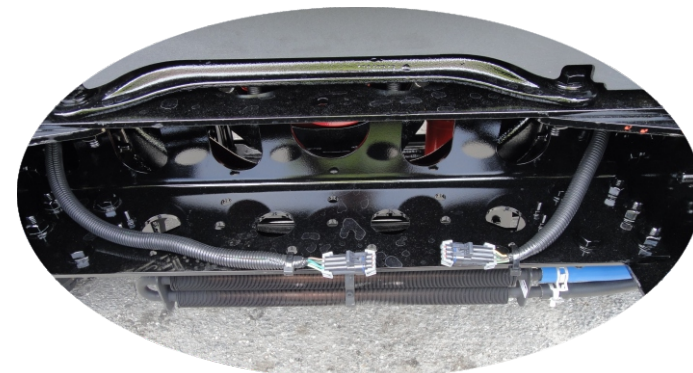

Dual connectors located near front crossmember

304-039 Snow Plow Headlight Dual Connector (RH Side)

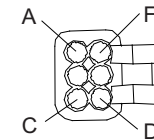

Mating connector supplied with Chassis
 Packard Connector PAC 12052848
 Terminal supplied by Body Builder
 Packard Terminal PAC 12048074
 Packard Seal Part# PAC 12059168

Connector Pin	Signal Name	Signal Type	Circuit Color	Circuit Number	Amperage
A	High Beam	Output	LTG	463H	30
B	Ground	Ground	LTG	463C	-
C	Low Beam	Output	LTG	463L	25
D	Marker Lamp	Output	BR	102C	10
E	Ground	Ground	BK	GND	-
F	Right Turn Signal	Output	DKG	38RP	-

304-038 Snow Plow Headlight Single Connector

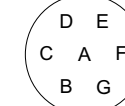

Mating connector supplied with Chassis
 Packard Connector PAC 12110751
 Terminal supplied by Body Builder
 Packard Terminal PAC 15304719
 Freightliner Seal Part# 23-12497-282

Connector Pin	Signal Name	Signal Type	Circuit Color	Circuit Number	Amperage
A	High Beam	Output	LTG	462K	30
B	Ground	Ground	BK	GND	-
C	Low Beam	Output	LTG	462J	25
D	Marker Lamp	Output	BR	102C	10
E	Right Turn Signal	Output	DKG	38RP	2.85
F	Left Turn Signal	Output	Y	38LP	2.85
G	-	-	-	-	-



Single connector can be found on LH frame rail near radiator
 Rev - B

SmartPlex Electrical System

SmartPlex Electrical System (35M module)

When ordered, the 35M SmartPlex module is a factory installed option that provides Truck Equipment Manufacturers (TEMs) ease of integration with Freightliner's multiplexed electrical system. TEM's can easily take advantage of information provided on the J1939 bus to create safety and interdependent interlocks with a simple program parameter versus having to cut into chassis wiring to install relays. This shortens installation time for TEM's and eliminates additional electrical connections that can be problematic in the field.

Included in 35M is a SmartPlex Hub Module and all the wiring necessary to make available twelve 20 amp outputs, ten 7 amp outputs and six ground inputs. The twelve 20A outputs are provided in the 12 pin connector and the 7 amp outputs and ground inputs are provided in the 16 pin connector. The connectors are located inside the cab behind the driver seat. The 20 amp outputs are fused and relayed in a relay module behind the driver seat. The 7 amp outputs are run directly through the SmartPlex Hub Module and are FET transistor protected in the module.

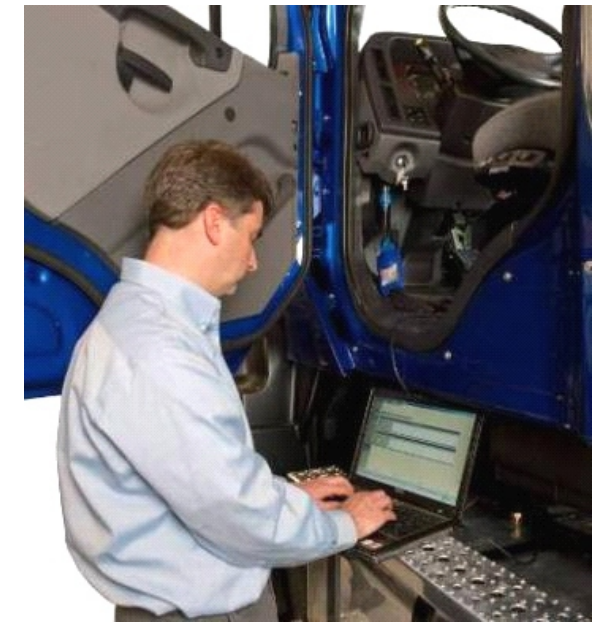

Note: Switches and indicator lamps are not functional as received from the factory and require programming. Each switch and indicator lamp will have a unique parameter providing the desired function. For example if you wanted switch #1 to turn on 20 amp output #1 only when the park brake was set you would program a specific parameter to accomplish this. Authorized dealers as well as trained equipment manufacturers with a body builder log in can program a vehicle. Equipment manufacturers can contact their dealer or the body builder support desk at 855-253-0426 for training.

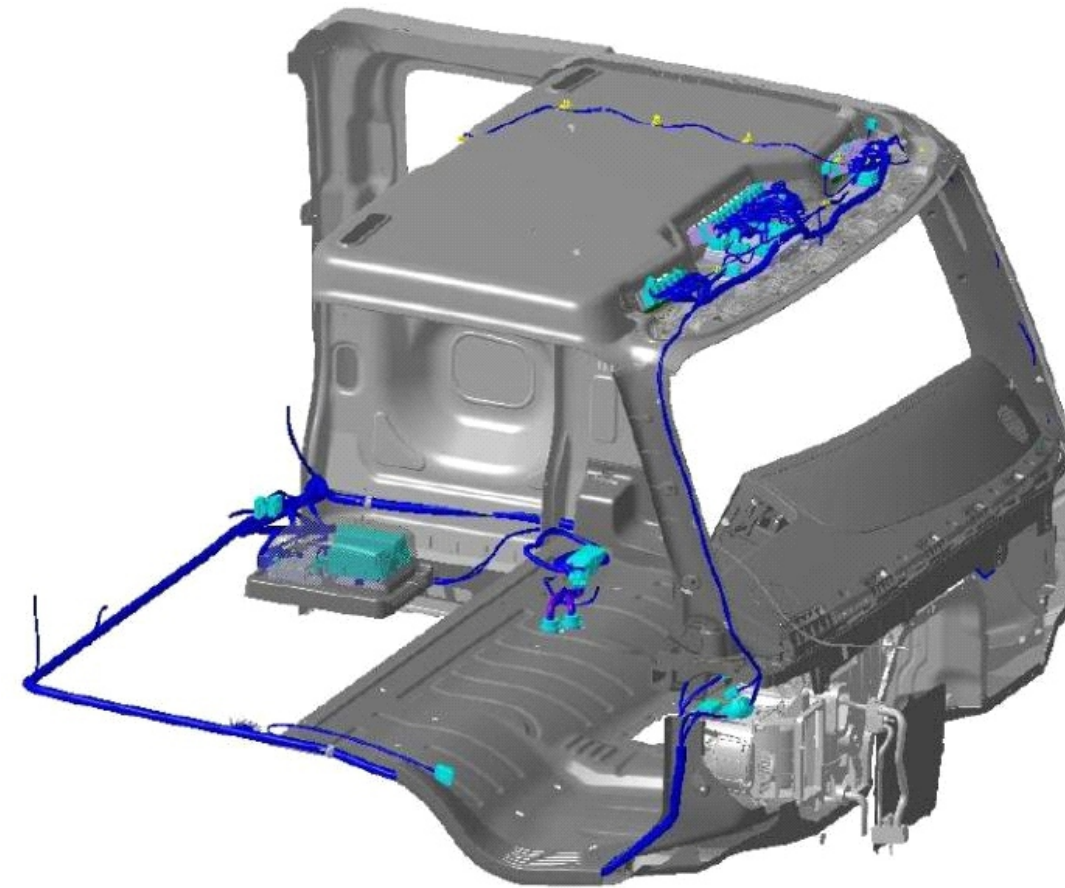

Extended Cab wired with SmartPlex

Overhead Console Configuration Possibilities			
Data Codes	Driver Side	Center Console	Passenger Side
35M-001 - SmartPlex Hub Mod w/Overhead Switch Mounting, Driver Side Only (6 Switch Slots)			
35M-002 - SmartPlex Hub Mod w/Overhead Switch Mounting, Pass Side Only (6 Switch Slots)			
35M-003 - SmartPlex Hub Mod w/Overhead Switch Mounting, Center Console (6 Switch Slots)			
35M-004 - SmartPlex Hub Mod w/Overhead Switch Mounting, Center Console (12 Switch Slots-No CB)			
35M-005 - SmartPlex Hub Mod w/Overhead Switch Mounting, Driver & Pass Side (12 Switch Slots)			
35M-006 - SmartPlex Hub Mod w/Overhead Switch Mounting, Driver Side & Center Console (12 Switch Slots)			
35M-007 - SmartPlex Hub Mod w/Overhead Switch Mounting, Driver Side (18 Switch Slots-No CB)			
35M-008 - SmartPlex Hub Mod w/Overhead Switch Mounting, Driver, Pass & Center Console (18 Switch Slots)			
35M-009 - SmartPlex Hub Mod w/Overhead Switch Mounting, Driver, Pass & Center Console (24 Switch Slots-No CB)			

There are 9 variations of the 35M SmartPlex module that can be ordered. The variations determine the quantity of the available switch locations provided in the vehicle overhead in multiples of 6 from 6 to 24.

2 position 3 position



Switches and indicator lamps are ordered separately from the 35M module. Switches are ordered by style and quantity. Indicator lamps are available for order in red, amber, or green. Some pre-labeled indicator lamps are also available for order. Switch lense inserts are provided based on the vocational use of the truck ordered. Custom lenses can be requested through Vencor Inc., (www.vencorinc.com).



TEM interface connectors



SmartPlex Electrical System

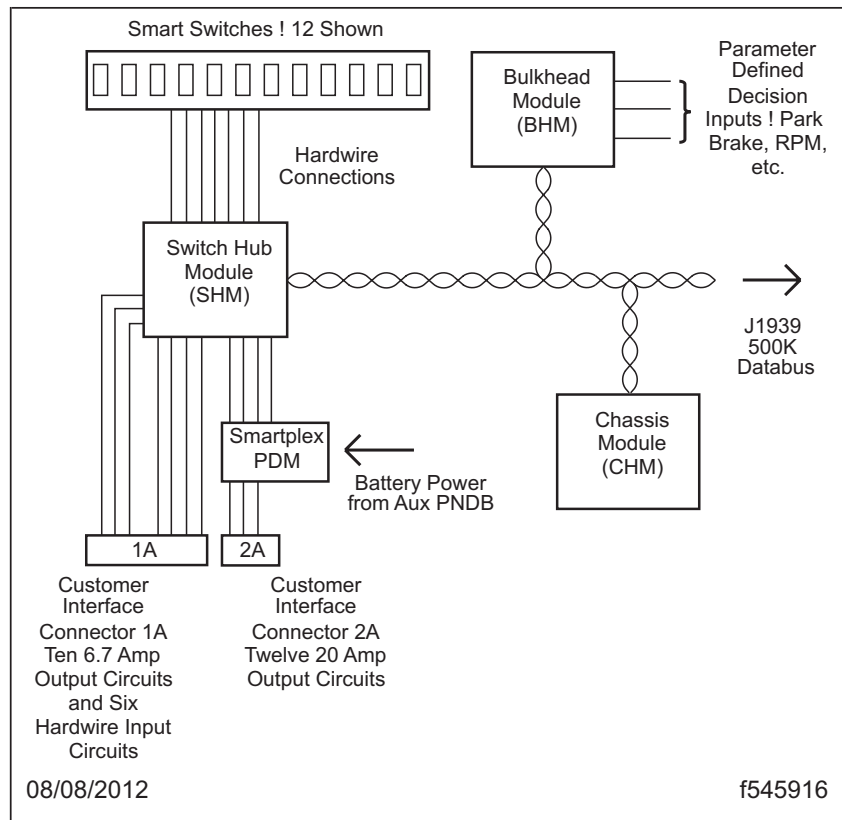

SmartplexSystemDiagram

Smartplex is a configurable system that allows a common set of electronic components to manage different options in various vehicle configurations. Smartplex allows the customer to select the switches needed for the vehicle, then configure the output circuits for specific functions. Smartplex allows up to 24 switches and indicators in the overhead console, and 6 hardwired input circuits, to control twelve 20-amp output circuits and ten 6.7-amp output circuits. Any combination of smart switches and hardwire input circuits can be configured to operate the output circuits that are wired to customer interface connector 1A, and customer interface connector 2A. The configuration is programmable with ServiceLink using parameters that can be accessed using the "Parameter Search Tool".

An authorized Freightliner dealer can provide programming or a truck equipment manufacturer with a body builder login id will have access to the "SmartPlex Parameter Search Tool" and "ServiceLink" to perform programming. You can contact the Body Builder Support desk at 855-253-0426 to receive instruction on requesting a login id as well as request additional training.

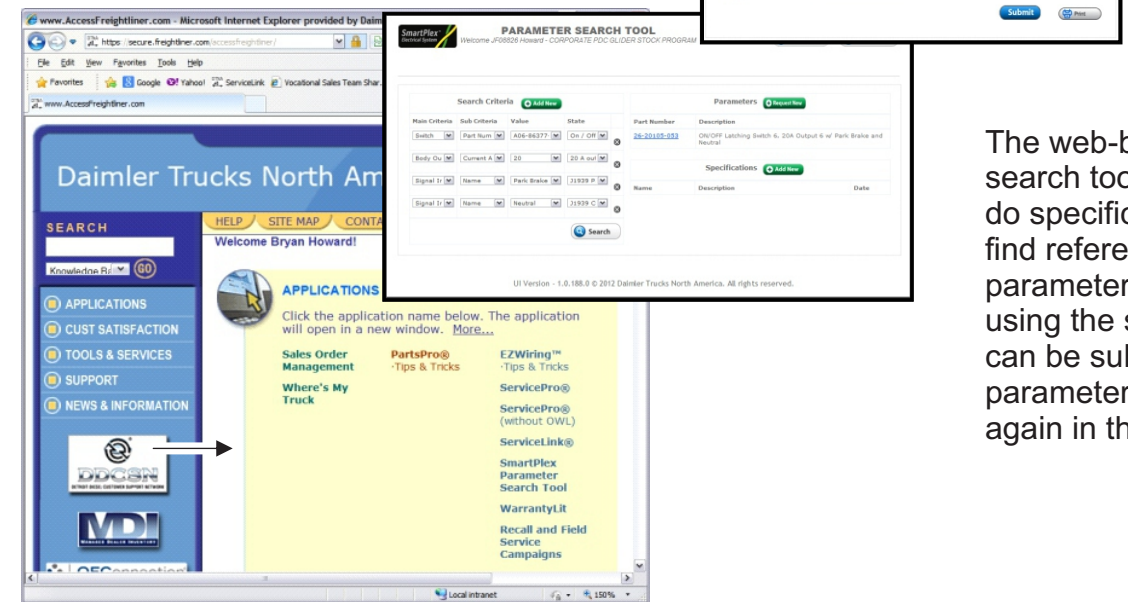

The web-based SmartPlex parameter search tool allows TEMs and dealers to do specific criteria based searches to find reference parameters. If a parameter does not currently exist using the search tool, a custom request can be submitted. Once this new parameter is created it can be used again in the future.

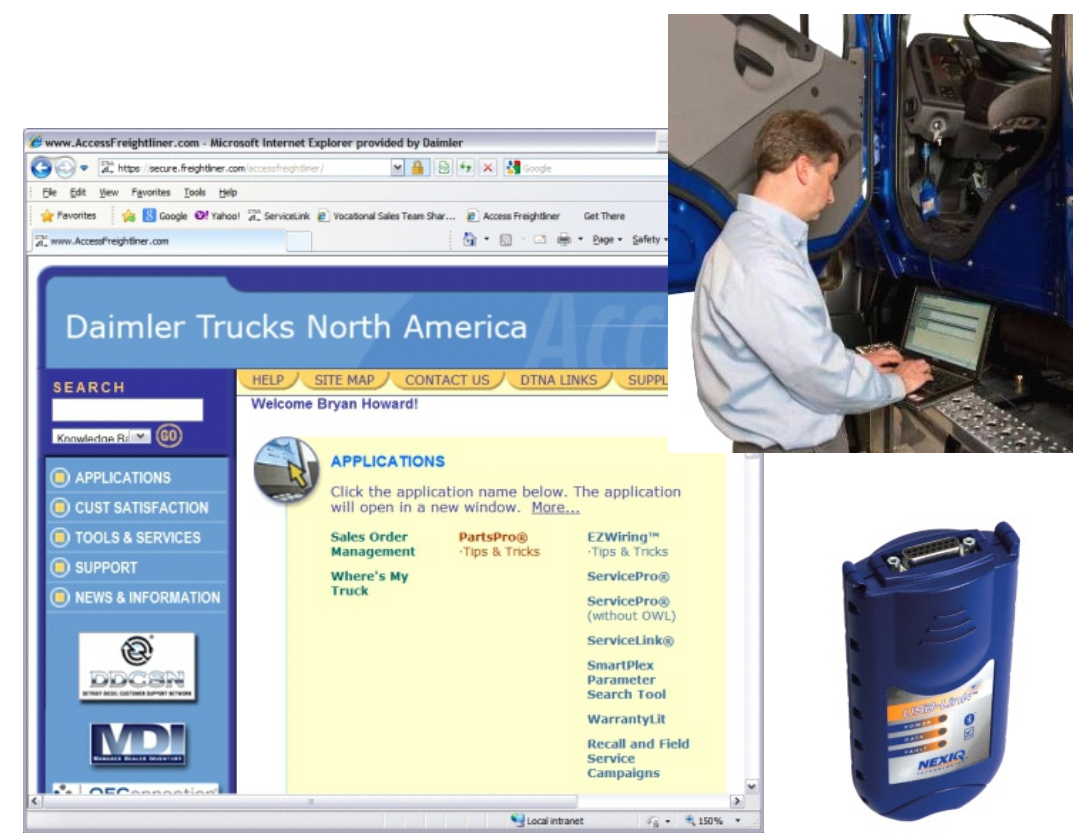

The SmartPlex system is programmed by using Freightliner's web based service tool called ServiceLink. An internet connection is required and connection to the vehicle is made using a laptop and a commercially available USB Link diagnostic connector. New Parameters are first saved to Freightliner's mainframe computer before loading them to the vehicle which provides the security of archiving the latest set of parameters. Again, a parameter programmed to the bulkhead module is required to make a switch functional.



SmartPlex Switch and Indicators

Each switch and indicator has its own unique part number.

Parameters are designed for specific switches and indicators.

- Note how the programming parameter aligns to the switch part number.
- For example all on/off latching switches have a part number that is A06-86377-100. If the truck was ordered with 2 on/off latching switches, the first 2 part numbers in this group would be provided so you would receive A06-86377-100 and A06-86377-101.
- An example of a parameter for the first on/off latching switch A06-86377-100 would be 26-20100-002. Which would provide the function of energizing 6.7amp output number 1 on customer interface connector 2A.

As you can see in the table below, any parameter beginning with the base number 26-20100-XXX will be to operate on/off latching switch #1 A06-86377-100 and as you change the last 3 numbers of the parameter, the function changes.

You can have only one parameter for a given switch or indicator. Because the switches and indicators are unique, you can not have an identical part number plugged into the SmartPlex system at the same time or an error will occur. You can however move a switch or indicator from one position to another without having to reprogram anything.

SmartPlex Electrical System

- 26-20100 - SmartPlex™ Parameter – ON/OFF Latching Switches
- 26-20200 - SmartPlex™ Parameter – ON/OFF Momentary Switches
- 26-20300 - SmartPlex™ Parameter – ON/OFF/ON Latching Switches
- 26-20400 - SmartPlex™ Parameter – ON/OFF/ON Momentary
- 26-20500 - SmartPlex™ Parameter – Indicators

Customer Interface Connector 2A

- 12 HSD 12V 20Amp Outputs

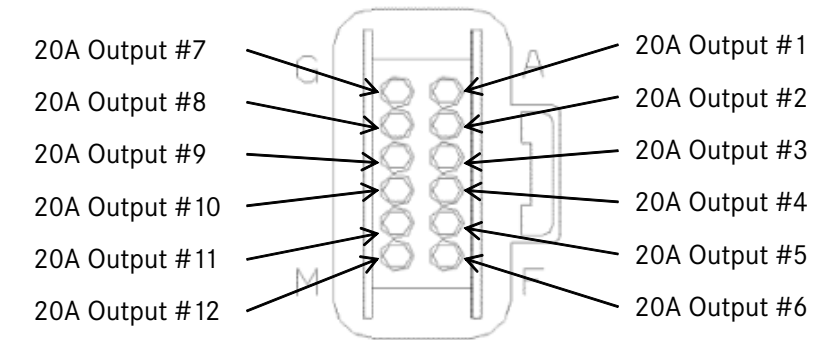

23-13144-004		PLUG-12CAV,GT280S,PAC15326910			
SERIES	GLOBAL TERMINAL 280 SEALED (GT280S)			SEALED	
CAV	12	GENDER	PLUG	COLOR	BLACK
MATL	PA6 GB20 GF10 HS	TPA	SEPARATE	CONN TYPE	INLINE
23-13212-120	TERM-FEM,GT280S,0.8-1(18-16)			APPROVED SUPPLIER PART NUMBERS PAC15304719	
23-13212-121	TERM-FEM,GT280S,2-3(14-12)			APPROVED SUPPLIER PART NUMBERS PAC15304720 - RESTRICTED USE	
23-13212-122	TERM-FEM,GT280S,5(10)			APPROVED SUPPLIER PART NUMBERS PAC15326004	

Customer Interface Connector 1A

- 6 Digital Ground Inputs
- 10 HSD 12V 7Amp Outputs

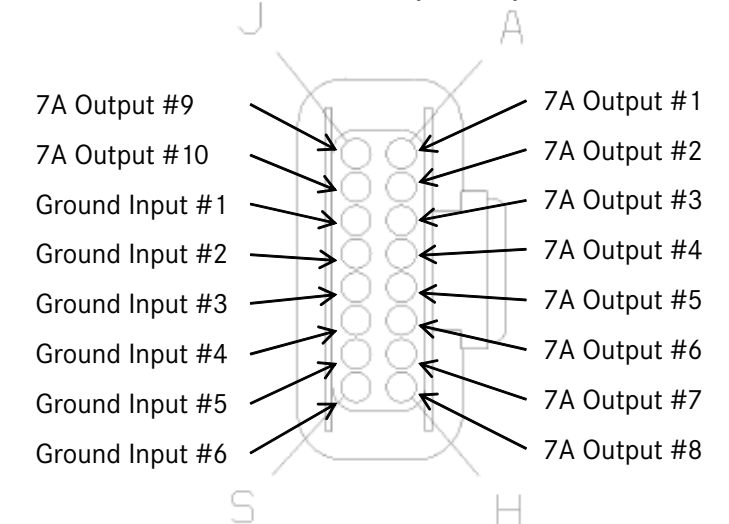

23-13144-016		PLUG-16CAV,GT150S,PAC15326863			
SERIES	GLOBAL TERMINAL 150 SEALED (GT150S)			SEALED	
CAV	16	GENDER	PLUG	COLOR	BLACK
MATL	PA6 GB20 GF10	TPA	SEPARATE	CONN TYPE	INLINE
23-13212-020	TERM-FEM,GT150S,0.8-1(18-16)			APPROVED SUPPLIER PART NUMBERS PAC12191819	
23-13212-021	TERM-FEM,GT150S,G-PLD,0.8-1			APPROVED SUPPLIER PART NUMBERS PAC15326427	
23-13212-022	TERM-FEM,GT150S,0.35-0.5			APPROVED SUPPLIER PART NUMBERS PAC12191818	

Service Parameters					
Reference Parameter	Description	Input	Part Number	Interlock	Output
26-20100-002	Turns on single output with Ignition Enabling when the switch is depressed	Smart-Switch ON/OFF Latching	A06-86377-100	- Ignition Enabling	6.7A Output 1
26-20100-003	Turns on single output with Ignition Enabling when the switch is depressed	Smart-Switch ON/OFF Latching	A06-86377-100	- Ignition Enabling	20A Output 1
26-20100-004	Turns on single output which is interlocked with park brake when the switch is depressed	Smart-Switch ON/OFF Latching	A06-86377-100	- Ignition Enabling - Park Brake Interlock	6.7A Output 1
26-20100-005	Turns on single output which is interlocked with park brake when the switch is depressed	Smart-Switch ON/OFF Latching	A06-86377-100	- Ignition Enabling - Park Brake Interlock	20A Output 1



SmartPlex Electrical System

SmartPlex Indicator Lamp Data Code Decoder

Data Code	Indicator Part Numbers	Indicator Part Numbers															
		Indicator ID Numbers															
		Data Code Description															
	A06-86377-500	A06-86377-501	A06-86377-502	A06-86377-503	A06-86377-504	A06-86377-505	A06-86377-506	A06-86377-507	A06-86377-600	A06-86377-601	A06-86377-602	A06-86377-603	A06-86377-604	A06-86377-605	A06-86377-606	A06-86377-607	A06-86377-608
	306	307	308	309	310	311	312	313	314	315	316	321	322	323	324	325	326
	IND LT-RED, BOOM OUT OF STOW	IND LT-RED, OUTRIGGER DEPLOYED	IND LT-RED, BODY UP	IND LT-RED, GATE OPEN	IND LT-RED, OFF	IND LT-GREEN, BATTERY ON	IND LT-GREEN, ON	IND LT-AMBER, CAUTION	IND LT-RED	IND LT-RED	IND LT-RED	IND LT-AMBER	IND LT-AMBER	IND LT-AMBER	IND LT-GREEN	IND LT-GREEN	IND LT-GREEN
44V-998	No SmartPlex Indicator Lamps																
44V-001	SmartPlex Indicator Lamp - Boom Out of Stow	x															
44V-002	SmartPlex Indicator Lamps - Boom Out of Stow & Outrigger Deployed	x	x														
44V-003	SmartPlex Indicator Lamps - Body Up & Gate Open			x	x												
44V-004	SmartPlex Indicator Lamp - Battery On					x											
44V-005	SmartPlex Indicator Lamps - On & Off				x		x										
44V-006	SmartPlex Indicator Lamp - On						x										
44V-007	SmartPlex Indicator Lamp - Off					x											
44V-008	SmartPlex Indicator Lamp - Caution							x									
44W-998	No SmartPlex Indicator Lamps																
44W-001	SmartPlex Indicator Lamps (0-Red, 0-Amber, 1-Green)														x		
44W-002	SmartPlex Indicator Lamps (0-Red, 0-Amber, 2-Green)														x	x	
44W-003	SmartPlex Indicator Lamps (0-Red, 0-Amber, 3-Green)														x	x	x
44W-010	SmartPlex Indicator Lamps (0-Red, 1-Amber, 0-Green)											x					
44W-011	SmartPlex Indicator Lamps (0-Red, 1-Amber, 1-Green)											x			x		
44W-012	SmartPlex Indicator Lamps (0-Red, 1-Amber, 2-Green)											x			x	x	
44W-013	SmartPlex Indicator Lamps (0-Red, 1-Amber, 3-Green)											x			x	x	x
44W-020	SmartPlex Indicator Lamps (0-Red, 2-Amber, 0-Green)											x	x				
44W-021	SmartPlex Indicator Lamps (0-Red, 2-Amber, 1-Green)											x	x		x		
44W-022	SmartPlex Indicator Lamps (0-Red, 2-Amber, 2-Green)											x	x		x	x	
44W-023	SmartPlex Indicator Lamps (0-Red, 2-Amber, 3-Green)											x	x		x	x	x
44W-030	SmartPlex Indicator Lamps (0-Red, 3-Amber, 0-Green)											x	x	x			
44W-031	SmartPlex Indicator Lamps (0-Red, 3-Amber, 1-Green)											x	x	x	x		
44W-032	SmartPlex Indicator Lamps (0-Red, 3-Amber, 2-Green)											x	x	x	x	x	
44W-033	SmartPlex Indicator Lamps (0-Red, 3-Amber, 3-Green)											x	x	x	x	x	x
44W-100	SmartPlex Indicator Lamps (1-Red, 0-Amber, 0-Green)								x								
44W-101	SmartPlex Indicator Lamps (1-Red, 0-Amber, 1-Green)								x						x		
44W-102	SmartPlex Indicator Lamps (1-Red, 0-Amber, 2-Green)								x						x	x	
44W-103	SmartPlex Indicator Lamps (1-Red, 0-Amber, 3-Green)								x						x	x	x
44W-110	SmartPlex Indicator Lamps (1-Red, 1-Amber, 0-Green)								x		x						
44W-111	SmartPlex Indicator Lamps (1-Red, 1-Amber, 1-Green)								x		x				x		
44W-112	SmartPlex Indicator Lamps (1-Red, 1-Amber, 2-Green)								x		x				x	x	
44W-113	SmartPlex Indicator Lamps (1-Red, 1-Amber, 3-Green)								x		x				x	x	x
44W-120	SmartPlex Indicator Lamps (1-Red, 2-Amber, 0-Green)								x		x	x					
44W-121	SmartPlex Indicator Lamps (1-Red, 2-Amber, 1-Green)								x		x	x			x		
44W-122	SmartPlex Indicator Lamps (1-Red, 2-Amber, 2-Green)								x		x	x			x	x	
44W-123	SmartPlex Indicator Lamps (1-Red, 2-Amber, 3-Green)								x		x	x			x	x	x
44W-130	SmartPlex Indicator Lamps (1-Red, 3-Amber, 0-Green)								x		x	x	x				
44W-131	SmartPlex Indicator Lamps (1-Red, 3-Amber, 1-Green)								x		x	x	x	x			
44W-132	SmartPlex Indicator Lamps (1-Red, 3-Amber, 2-Green)								x		x	x	x	x	x		

SmartPlex Switch Data Code Decoder

Data Code	Switch Part Numbers	Switch Part Numbers																							
		Smart Switch ID Numbers																							
		Data Code Description																							
	A06-86377-100	A06-86377-101	A06-86377-102	A06-86377-103	A06-86377-104	A06-86377-105	A06-86377-106	A06-86377-107	A06-86377-108	A06-86377-109	A06-86377-200	A06-86377-201	A06-86377-202	A06-86377-203	A06-86377-204	A06-86377-300	A06-86377-301	A06-86377-302	A06-86377-303	A06-86377-304	A06-86377-400	A06-86377-401	A06-86377-402	A06-86377-403	A06-86377-404
	273	274	275	276	277	278	279	280	281	282	283	284	289	290	291	292	293	294	295	296	297	298	299	300	305
	SW-RCKR, 2 POS LAT, W INDIC	SW-RCKR, 2 POS LAT, W INDIC	SW-RCKR, 2 POS LAT, W INDIC	SW-RCKR, 2 POS LAT, W INDIC	SW-RCKR, 2 POS LAT, W INDIC	SW-RCKR, 2 POS LAT, W INDIC	SW-RCKR, 2 POS LAT, W INDIC	SW-RCKR, 2 POS LAT, W INDIC	SW-RCKR, 2 POS LAT, W INDIC	SW-RCKR, 2 POS LAT, W INDIC	SW-RCKR, 2 POS MOM, W INDIC	SW-RCKR, 2 POS MOM, W INDIC	SW-RCKR, 2 POS MOM, W INDIC	SW-RCKR, 2 POS MOM, W INDIC	SW-RCKR, 2 POS MOM, W INDIC	SW-RCKR, 3 POS LAT	SW-RCKR, 3 POS LAT	SW-RCKR, 3 POS LAT	SW-RCKR, 3 POS LAT	SW-RCKR, 3 POS LAT	SW-RCKR, 3 POS MOM	SW-RCKR, 3 POS MOM	SW-RCKR, 3 POS MOM	SW-RCKR, 3 POS MOM	SW-RCKR, 3 POS MOM
44R-998	No On/Off Latching SmartPlex Switches																								
44R-001	1 On/Off Latching SmartPlex Switch	x																							
44R-002	2 On/Off Latching SmartPlex Switches	x	x																						
44R-003	3 On/Off Latching SmartPlex Switches	x	x	x																					
44R-004	4 On/Off Latching SmartPlex Switches	x	x	x	x																				
44R-005	5 On/Off Latching SmartPlex Switches	x	x	x	x	x																			
44R-006	6 On/Off Latching SmartPlex Switches	x	x	x	x	x	x																		
44R-007	7 On/Off Latching SmartPlex Switches	x	x	x	x	x	x	x																	
44R-008	8 On/Off Latching SmartPlex Switches	x	x	x	x	x	x	x	x																
44R-009	9 On/Off Latching SmartPlex Switches	x	x	x	x	x	x	x	x	x															
44R-010	10 On/Off Latching SmartPlex Switches	x	x	x	x	x	x	x	x	x	x														
44S-998	No On/Off Momentary SmartPlex Switches																								
44S-001	1 On/Off Momentary SmartPlex Switch															x									
44S-002	2 On/Off Momentary SmartPlex Switches															x	x								
44S-003	3 On/Off Momentary SmartPlex Switches															x	x	x							
44S-004	4 On/Off Momentary SmartPlex Switches															x	x	x	x						
44S-005	5 On/Off Momentary SmartPlex Switches															x	x	x	x	x					
44T-998	No On/Off/On Latching SmartPlex Switches																								
44T-001	1 On/Off/On Latching SmartPlex Switch															x									
44T-002	2 On/Off/On Latching SmartPlex Switches															x	x								
44T-003	3 On/Off/On Latching SmartPlex Switches															x	x	x							
44T-004	4 On/Off/On Latching SmartPlex Switches															x	x	x	x						
44T-005	5 On/Off/On Latching SmartPlex Switches															x	x	x	x	x					
44U-998	No On/Off/On Momentary SmartPlex Switches																								
44U-001	1 On/Off/On Momentary SmartPlex Switch																					x			
44U-002	2 On/Off/On Momentary SmartPlex Switches																					x	x		
44U-003	3 On/Off/On Momentary SmartPlex Switches																					x	x	x	
44U-004	4 On/Off/On Momentary SmartPlex Switches																					x	x	x	x
44U-005	5 On/Off/On Momentary SmartPlex Switches																					x	x	x	x



SmartPlex Schematic Dash

SmartPlex Electrical System

SmartPlex Schematic Overhead

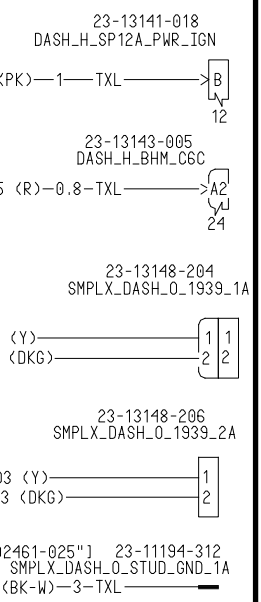
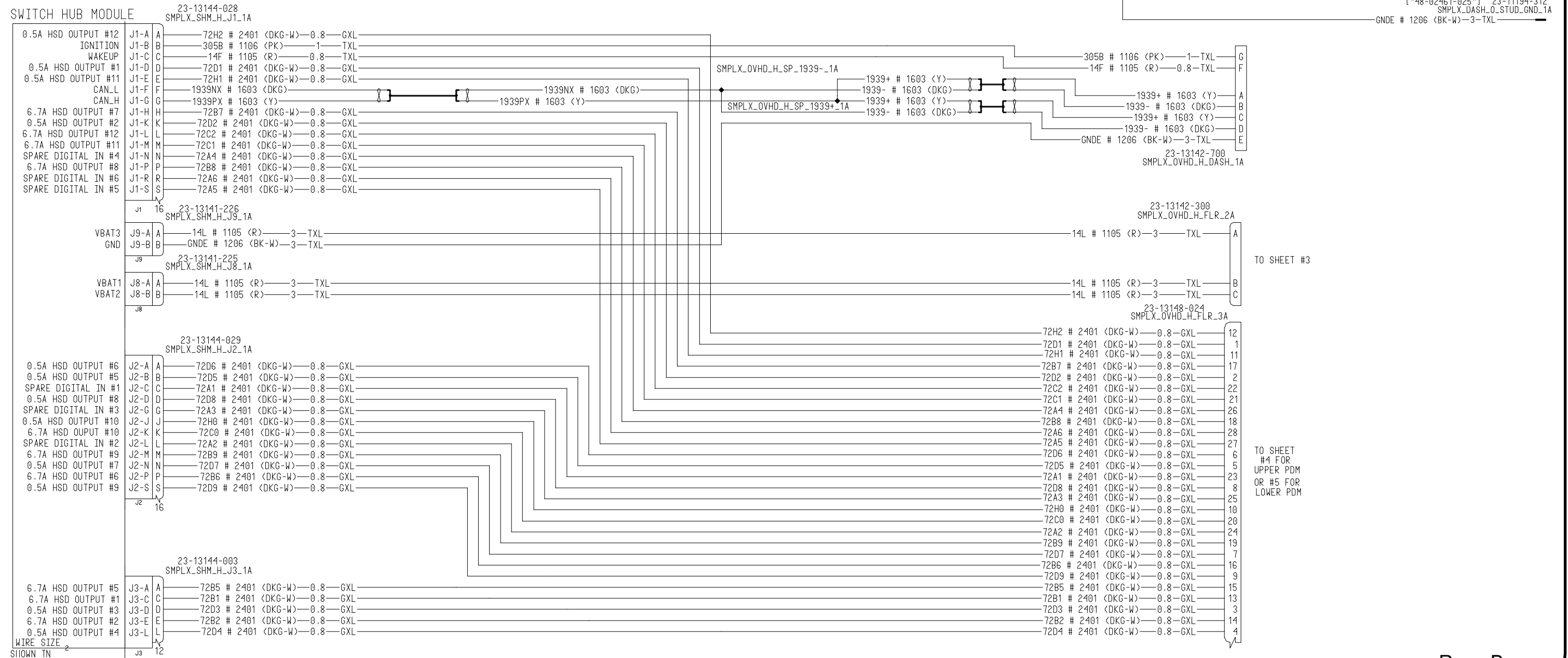

TO SHEET #3

TO SHEET #4 FOR UPPER PDM OR #5 FOR LOWER PDM

Rev - B



SmartPlex Schematic Backwall

SmartPlex Electrical System

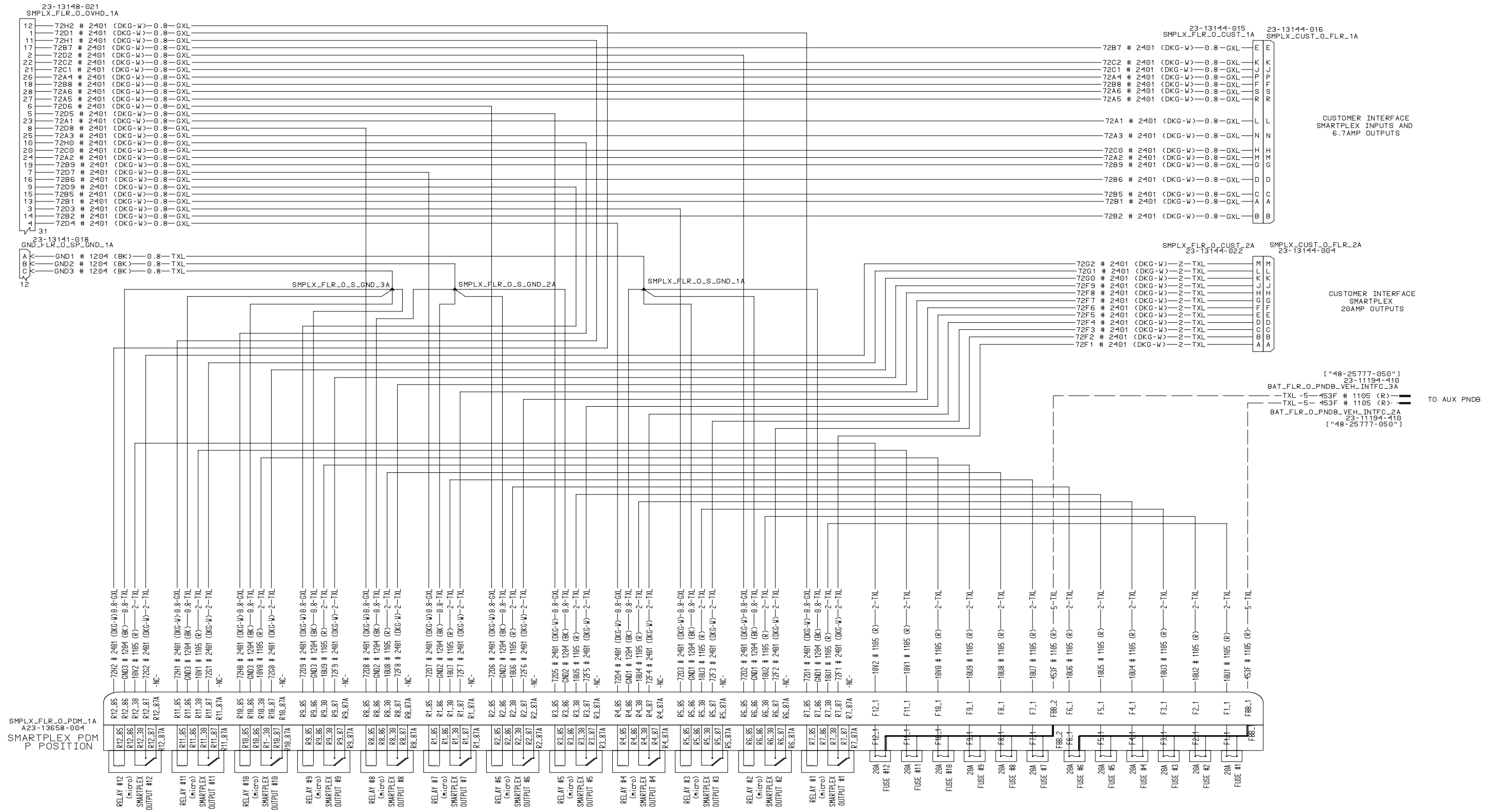

SMARTPLEX (MUX CTRL) FLOOR

Rev - B